

Marta Garrido García
Prof. Víctor A. Lafuente Sánchez

Diseño a base de puntos
Design based on points

tallerdediseño

1

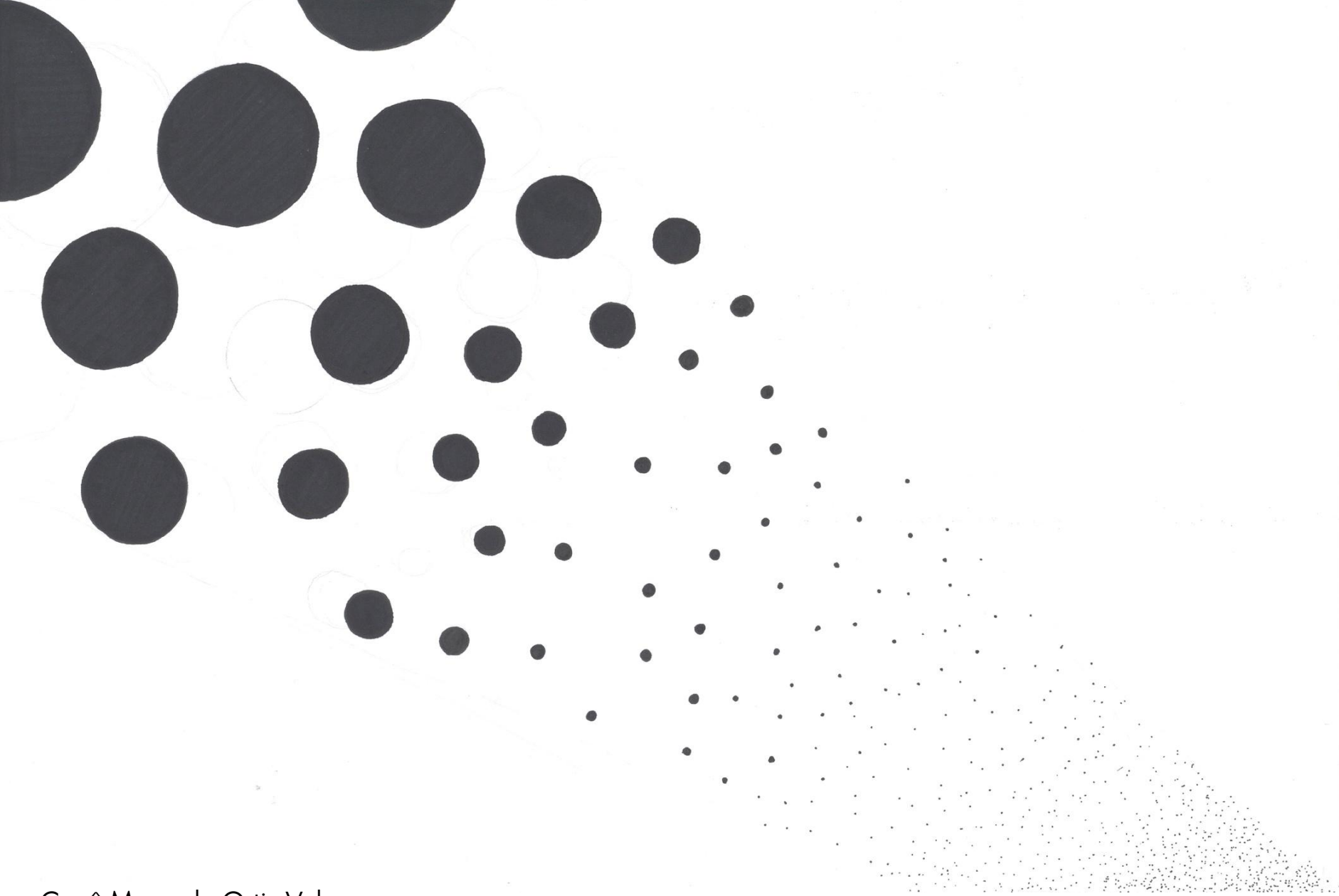

Cauê Massuda Ortiz Volpe
Prof. Víctor A. Lafuente Sánchez

Diseño a base de puntos
Design based on points

tallerdediseño



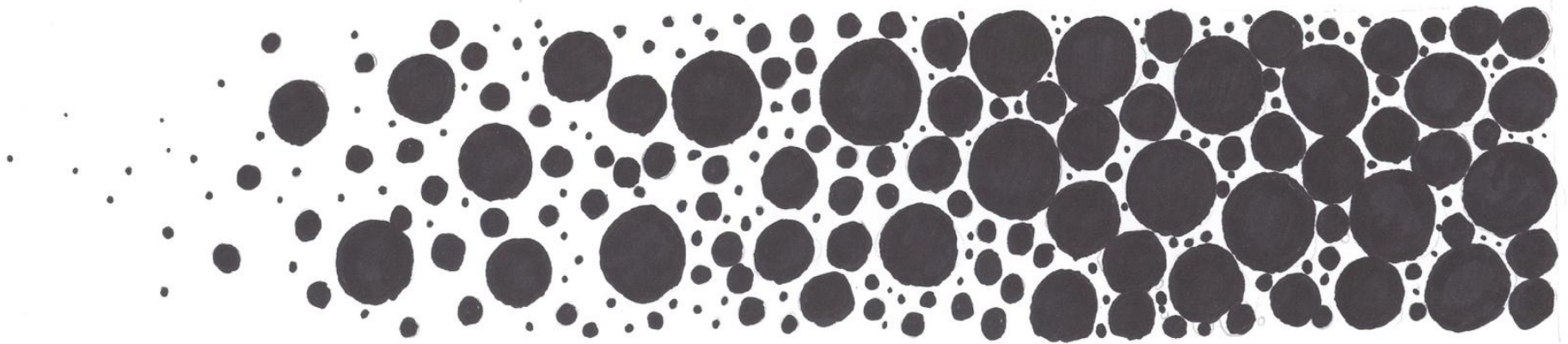

José Juan Esteban Higelmo
Prof. Víctor A. Lafuente Sánchez

Diseño a base de puntos
Design based on points

tallerdediseño

1

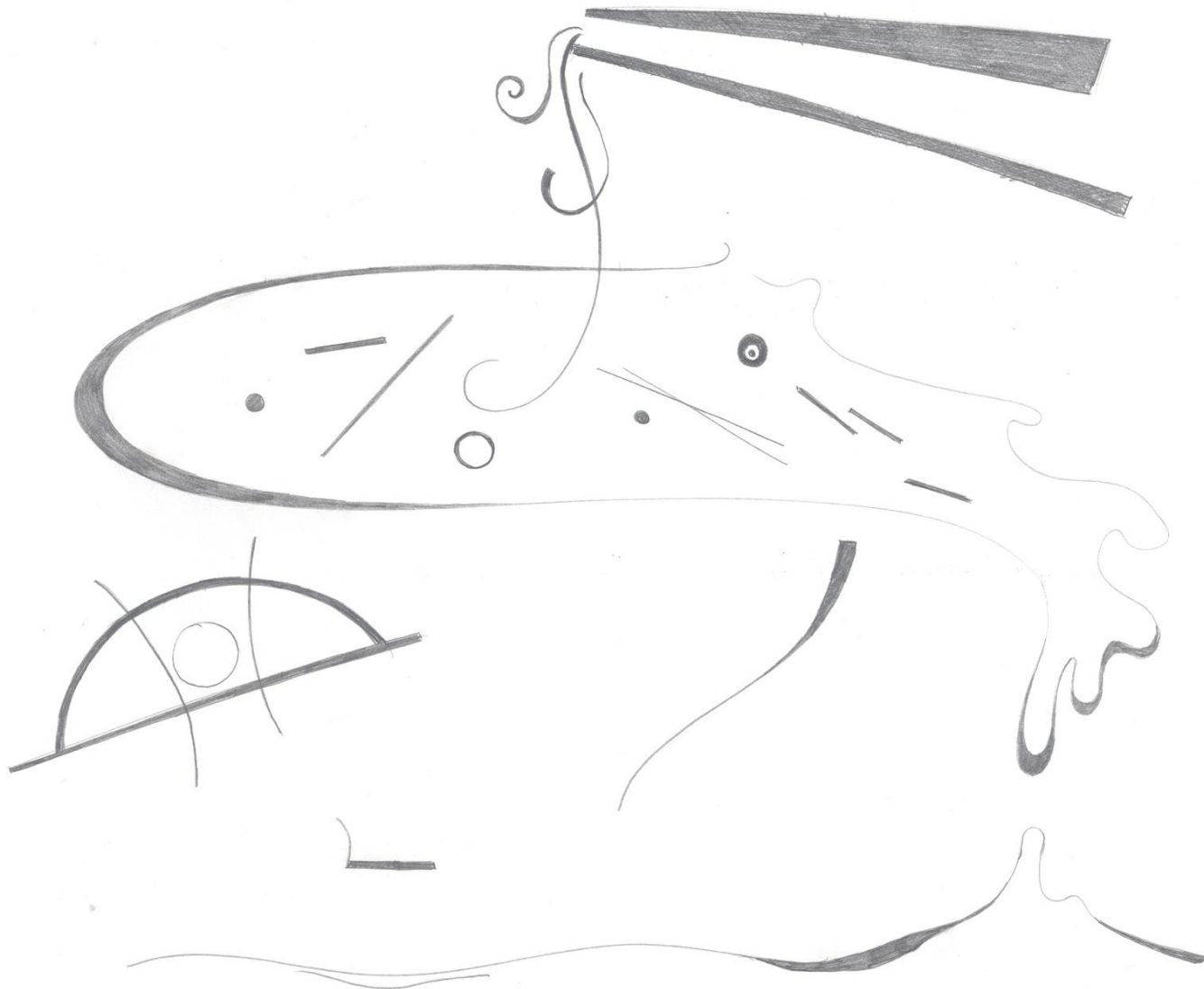

Marta Garrido García
Prof. Víctor A. Lafuente Sánchez

Diseño a base de líneas
Design based on lines

tallerdediseño

1

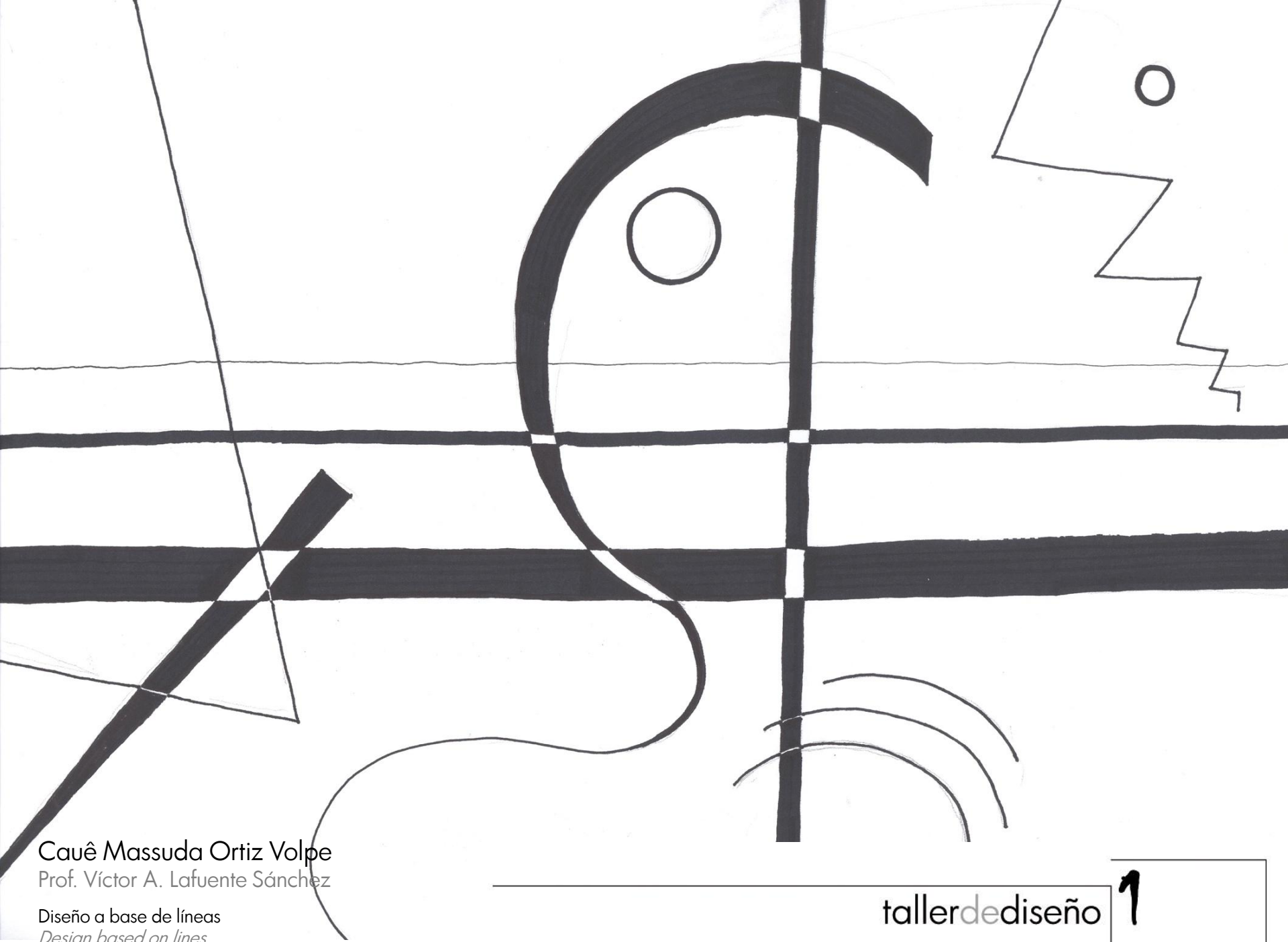

Cauê Massuda Ortiz Volpe
Prof. Víctor A. Lafuente Sánchez

Diseño a base de líneas
Design based on lines

tallerdediseño



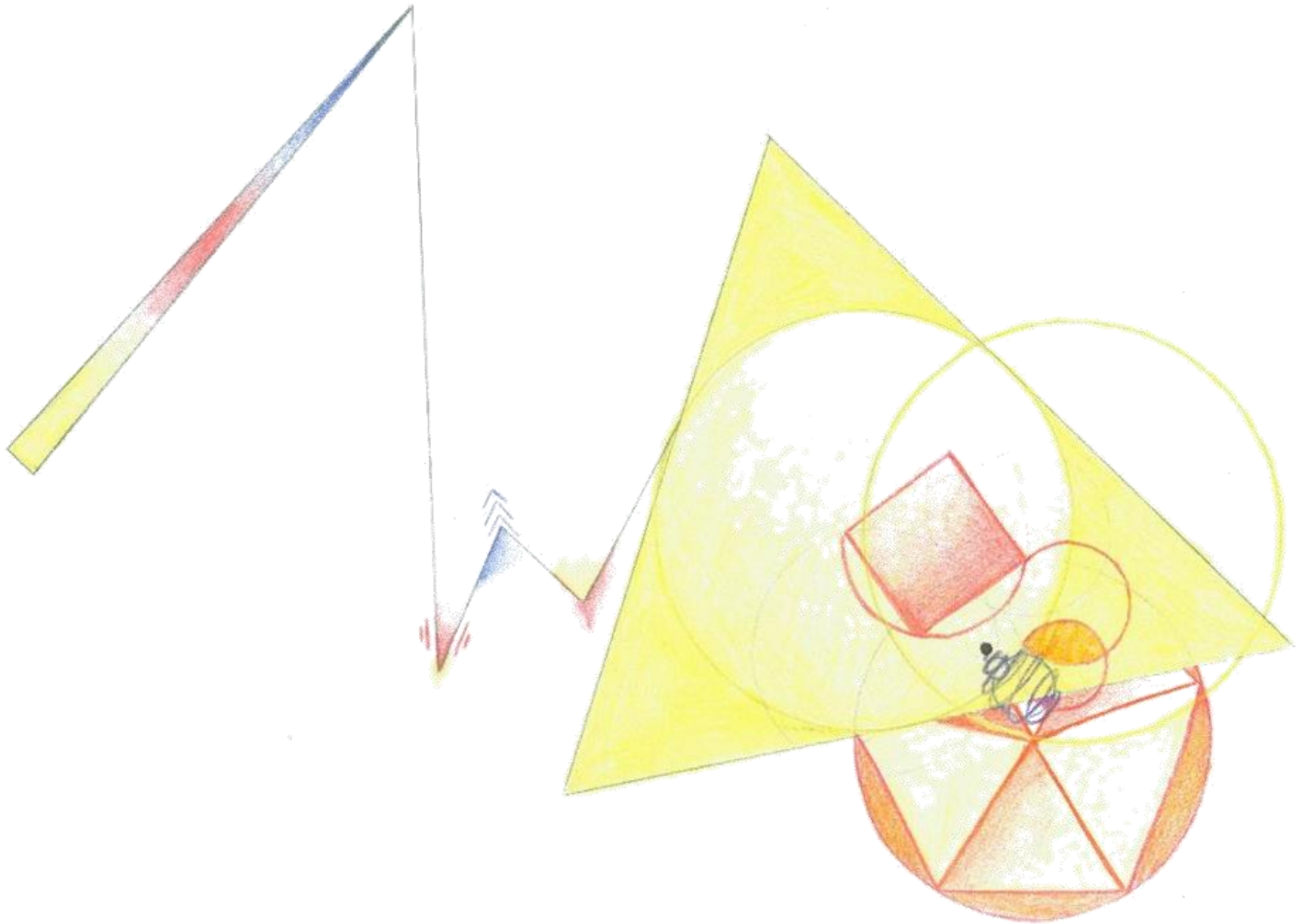

Carlos Martín Onís

Prof. Víctor A. Lafuente Sánchez

Explicación del movimiento de una peonza con formas básicas
Explanation of top motion from basic shapes

tallerdediseño

1

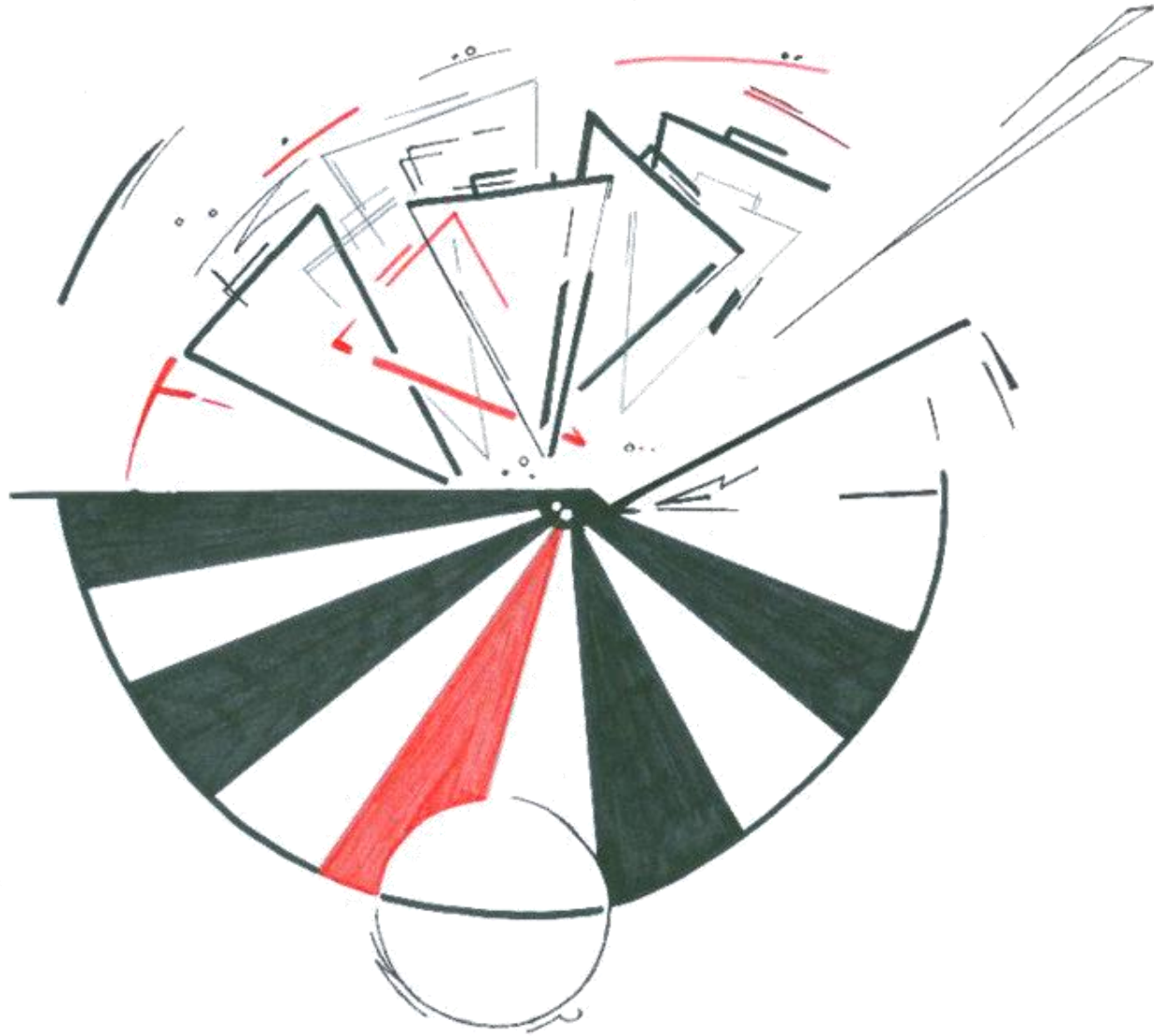

Jaime Perales García
Prof. Víctor A. Lafuente Sánchez

Explicación del movimiento de una peonza con formas básicas
Explanation of top motion from basic shapes

tallerdediseño

1

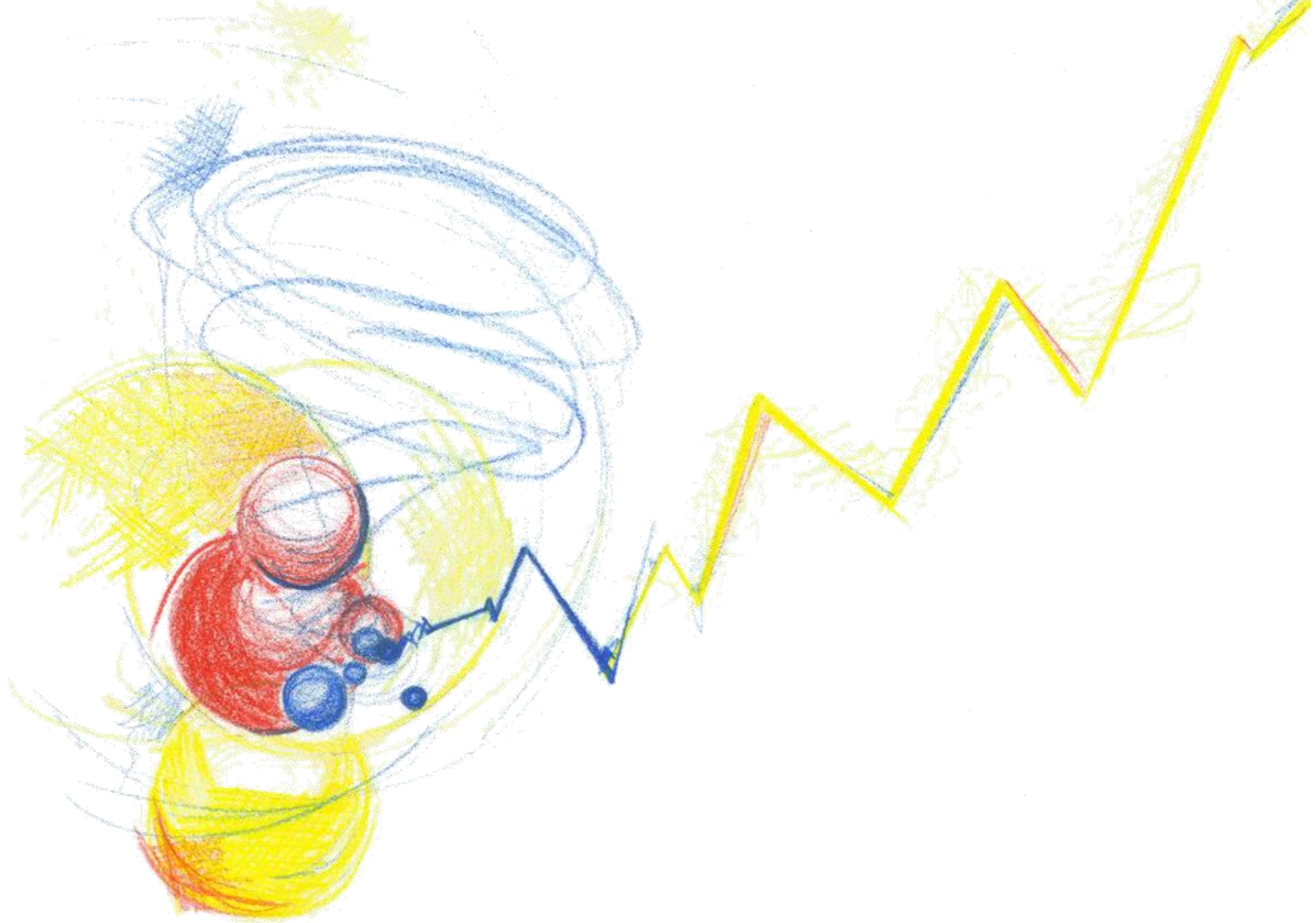

Álvaro Lucas Santos
Prof. Víctor A. Lafuente Sánchez

Explicación del movimiento de una peonza con formas básicas
Explanation of top motion from basic shapes

tallerdediseño

1

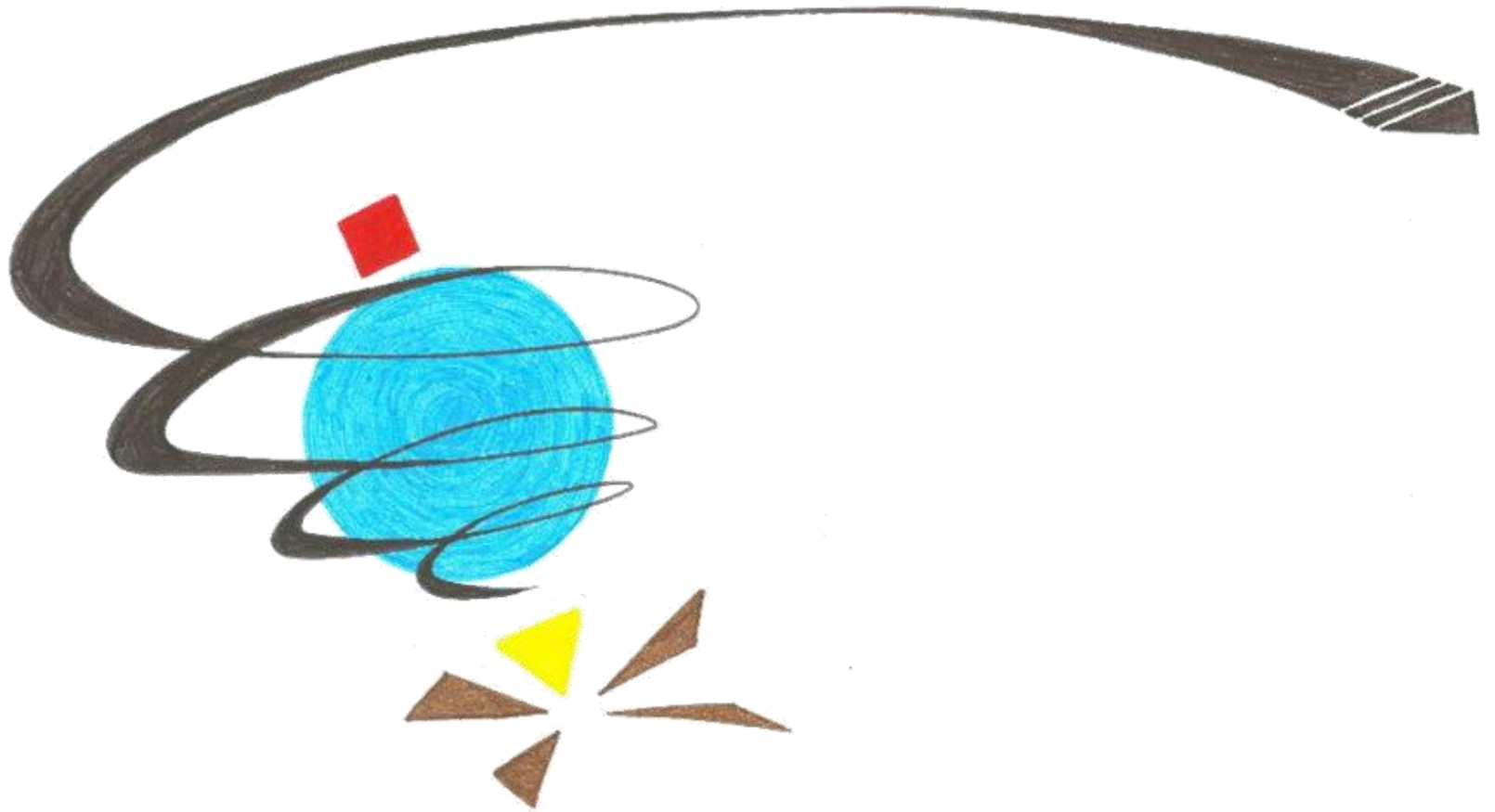

Mariano José Salazar Lozano
Prof. Víctor A. Lafuente Sánchez

Explicación del movimiento de una peonza con formas básicas
Explanation of top motion from basic shapes

tallerdediseño

1

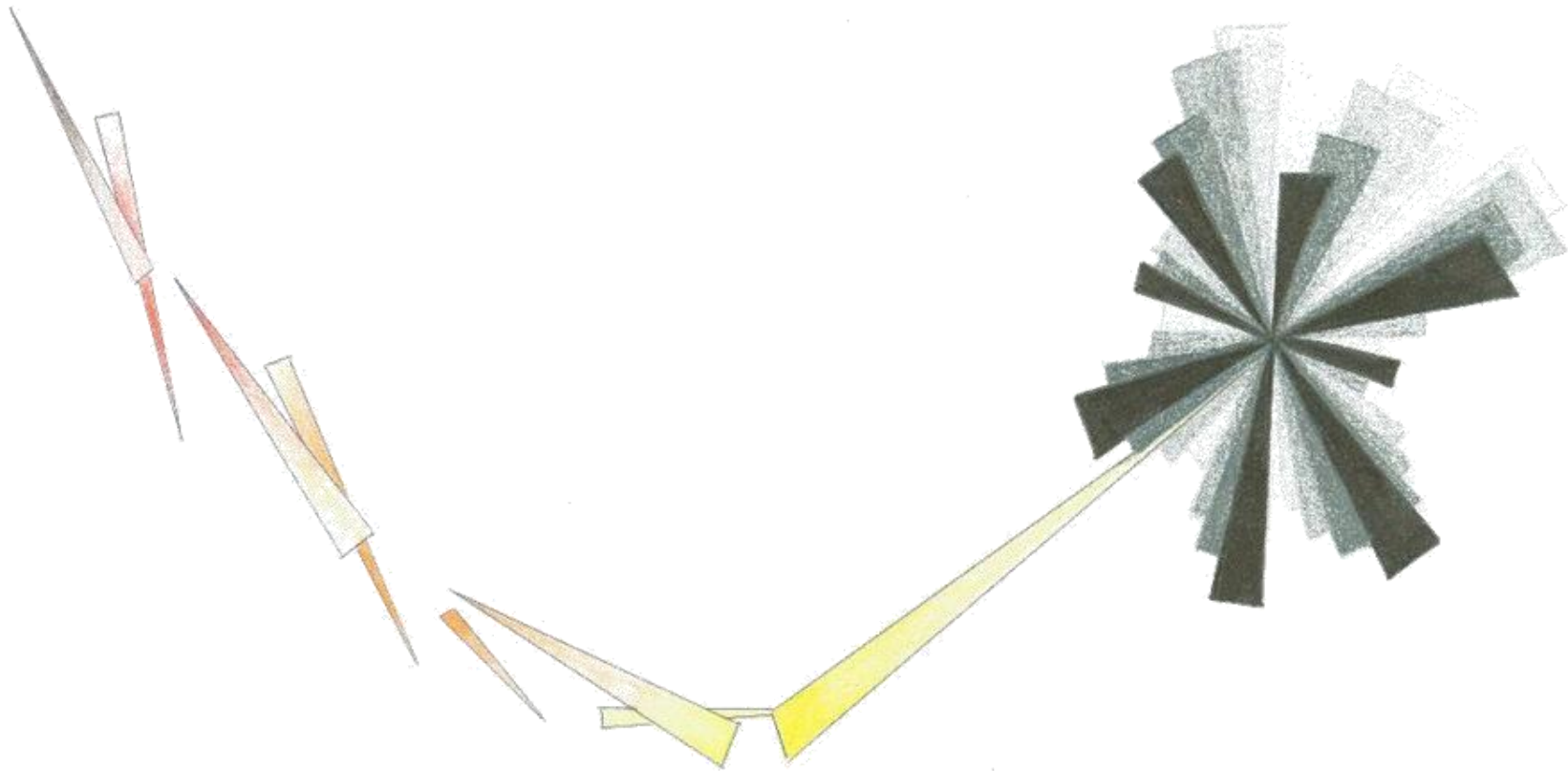

Laura Sanz Cañal

Prof. Víctor A. Lafuente Sánchez

Explicación del movimiento de una peonza con formas básicas
Explanation of top motion from basic shapes

tallerdediseño

1

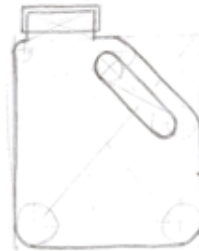
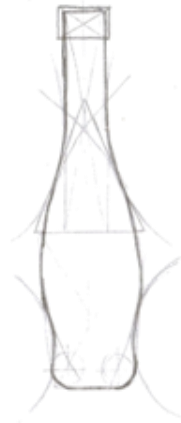

AGUA



CAFÉ



ACEITE

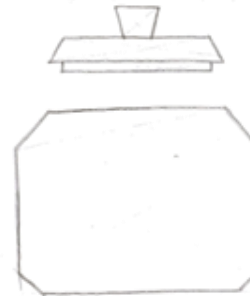

AZÚCAR



MAYONESA

Miguel Carbayo Viejo
Prof. Víctor A. Lafuente Sánchez

Análisis y diseño de recipientes para diferentes sustancias
Analysis and design of vessels for different substances

tallerdediseño

1

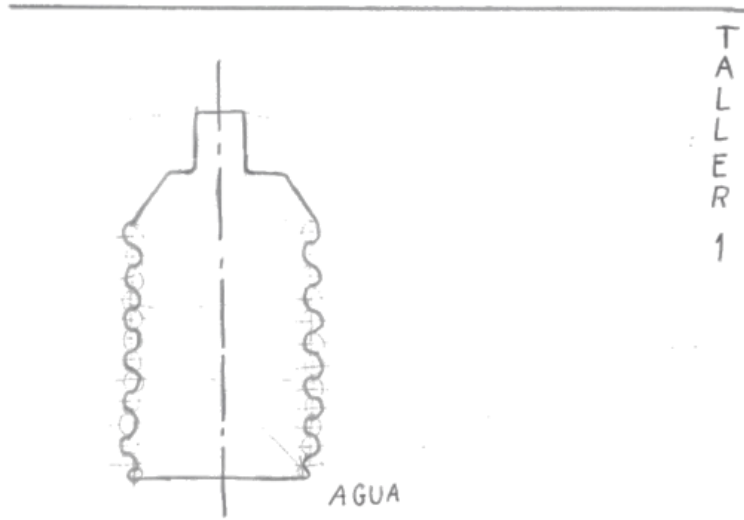

AGUA



CAFÉ

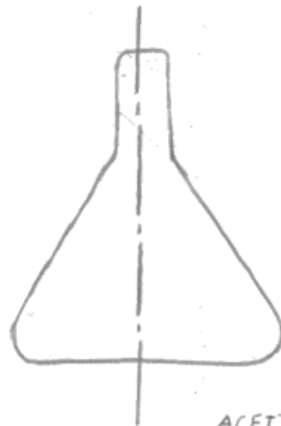

ACEITE

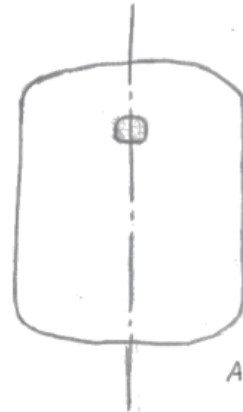

AZUCAR



MAYONESA



TALLER 1

RODRIGO

DOMÍNGUEZ FERNÁNDEZ
PRÁCTICA 3

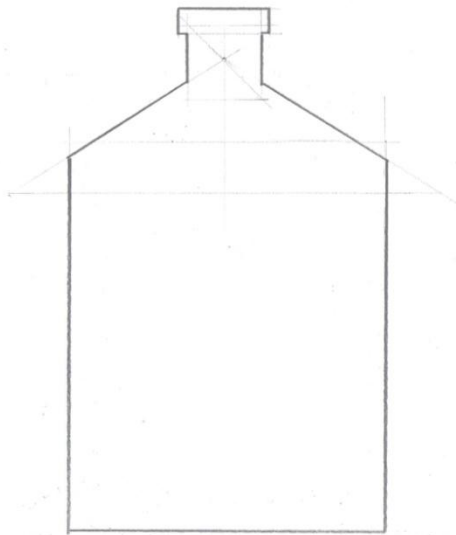

AGUA

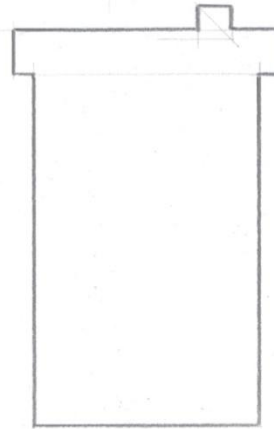

CAFÉ

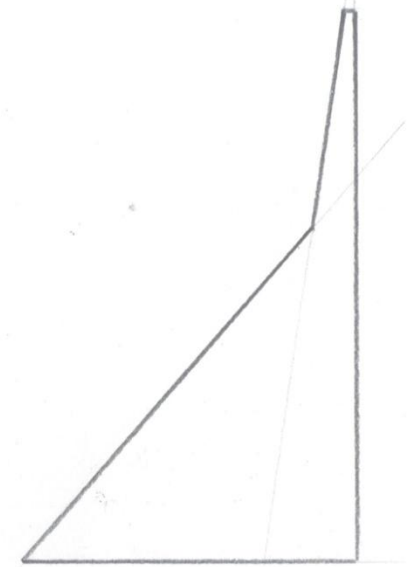

ACEITE

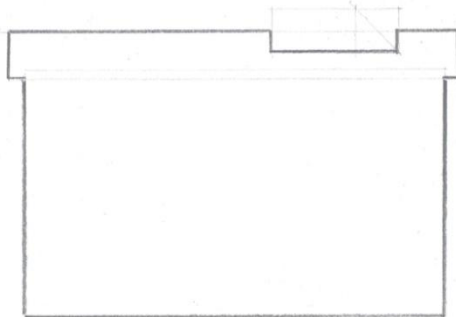

AZÚCAR



MAYONESA

Jorge Jiménez Gutiérrez
Prof. Víctor A. Lafuente Sánchez

Análisis y diseño de recipientes para diferentes sustancias
Analysis and design of vessels for different substances

tallerdediseño

1

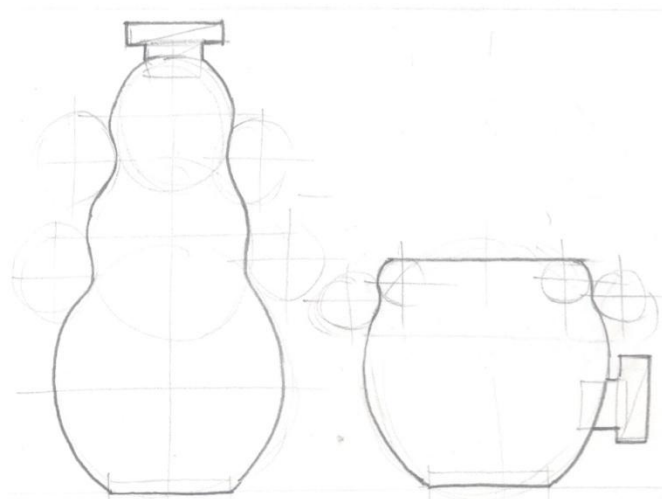
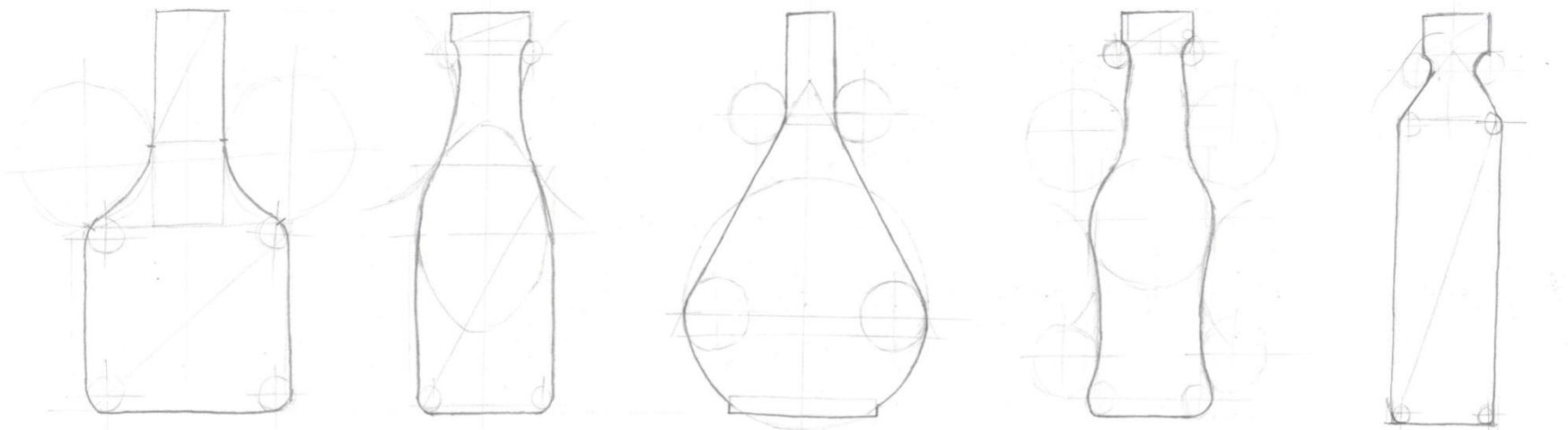

AGUA

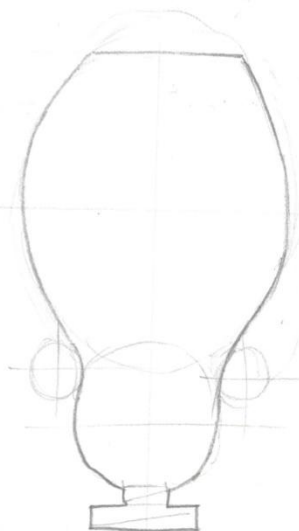
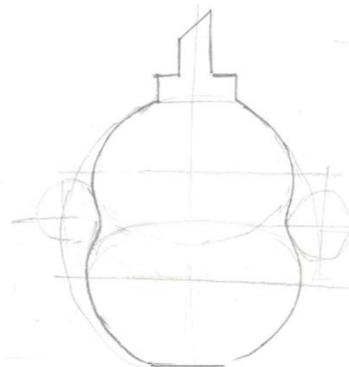
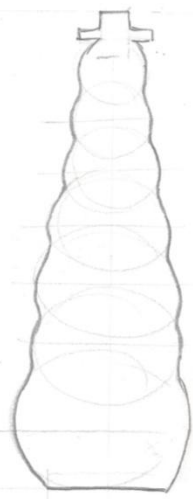

MAYONESA

Marta Garrido García

Prof. Víctor A. Lafuente Sánchez

Análisis y diseño de recipientes para diferentes sustancias
Analysis and design of vessels for different substances

tallerdediseño

1

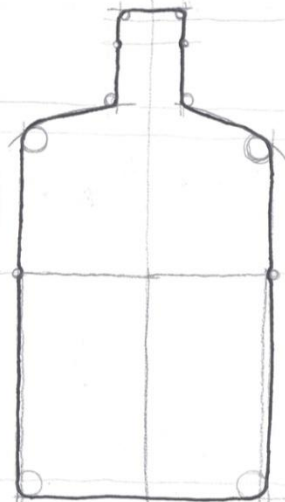
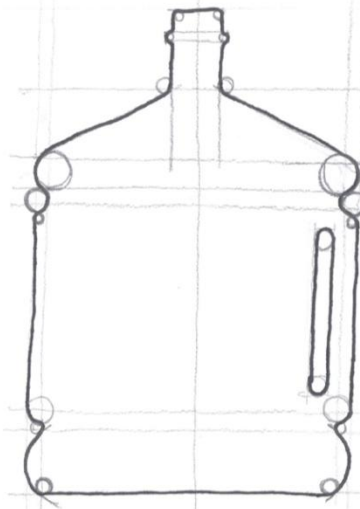
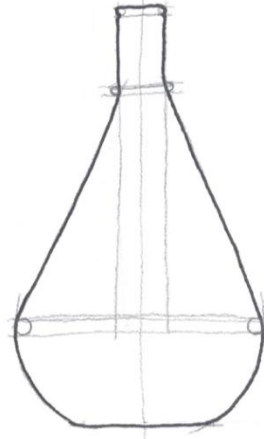
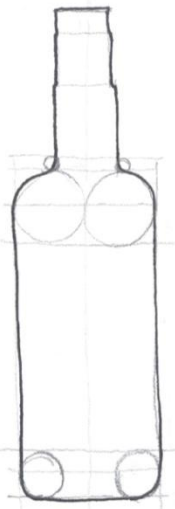
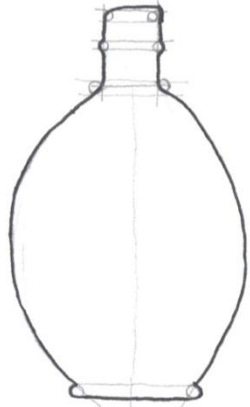

agua



aceite

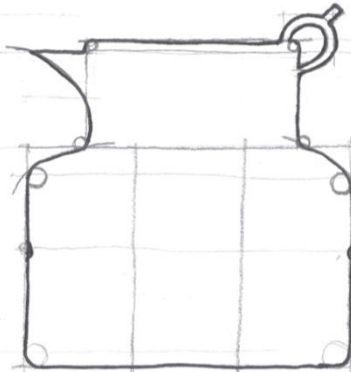

azúcar
café

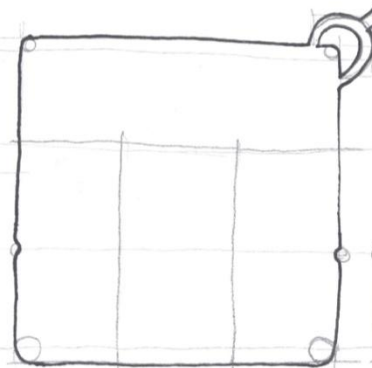

azúcar

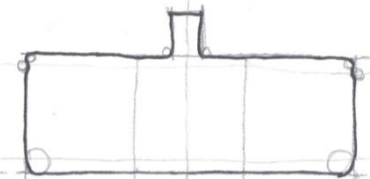

mantequilla

Cauê Massuda Ortiz Volpe
Prof. Víctor A. Lafuente Sánchez

Análisis y diseño de recipientes para diferentes sustancias
Analysis and design of vessels for different substances

tallerdediseño

1



Álvaro Blanco López

Prof. Víctor A. Lafuente Sánchez

Composiciones a base de puntos, líneas y planos
Compositions based on points, lines and planes

tallerdediseño

1

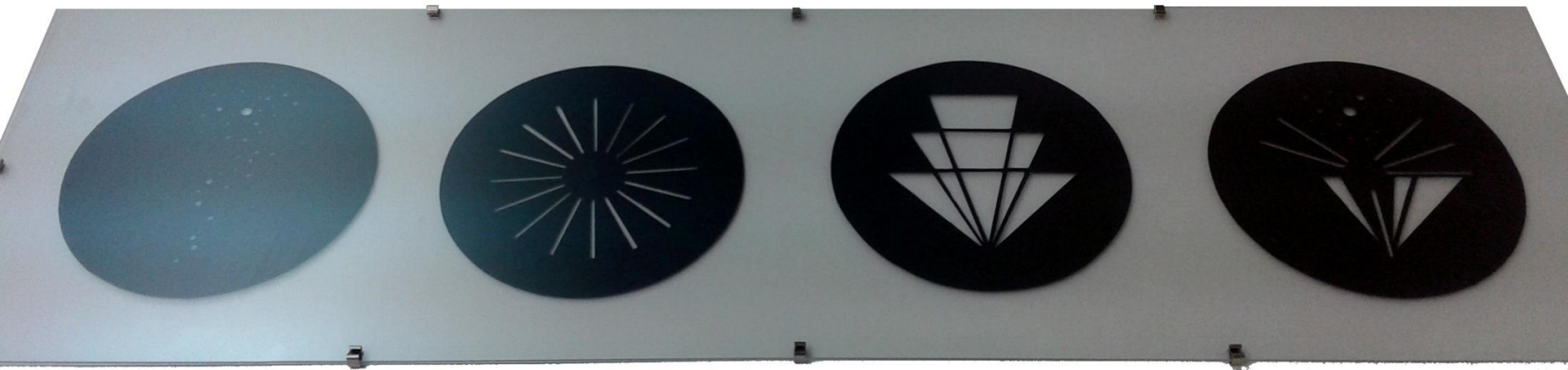

Marta Garrido García
Prof. Víctor A. Lafuente Sánchez

Composiciones a base de puntos, líneas y planos
Compositions based on points, lines and planes

tallerdediseño

1



Andrea Denis Carel Ayuso
Prof. Víctor A. Lafuente Sánchez

Composiciones a base de puntos, líneas y planos
Compositions based on points, lines and planes

tallerdediseño

1



Cauê Massuda Ortiz Volpe
Prof. Víctor A. Lafuente Sánchez

Composiciones a base de puntos, líneas y planos
Compositions based on points, lines and planes

tallerdediseño

1

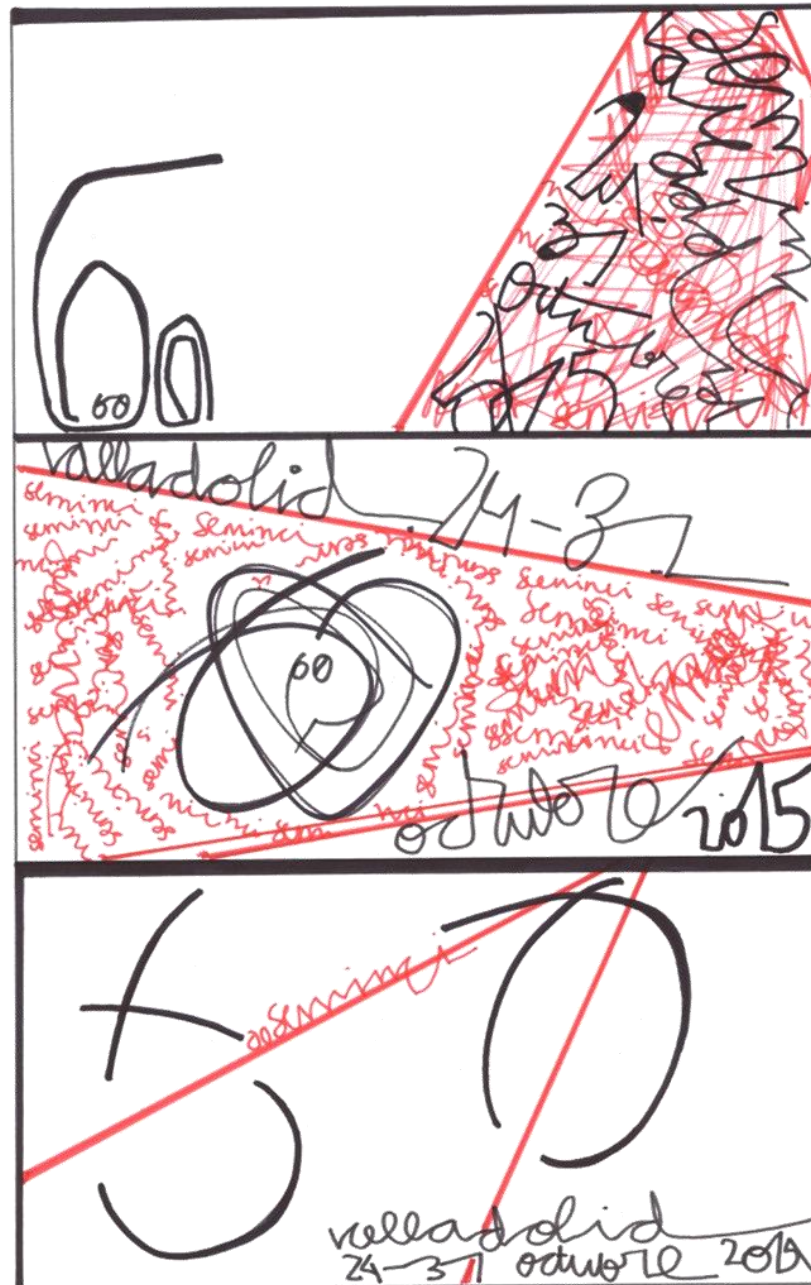

Álvaro Lucas Santos
 Prof. Víctor A. Lafuente Sánchez

Cartelería para la 60 Seminci a partir del esquema de peso visual de tres fotografías
Posters for 60 Seminci from visual weight scheme of three photographs

tallerdediseño

1

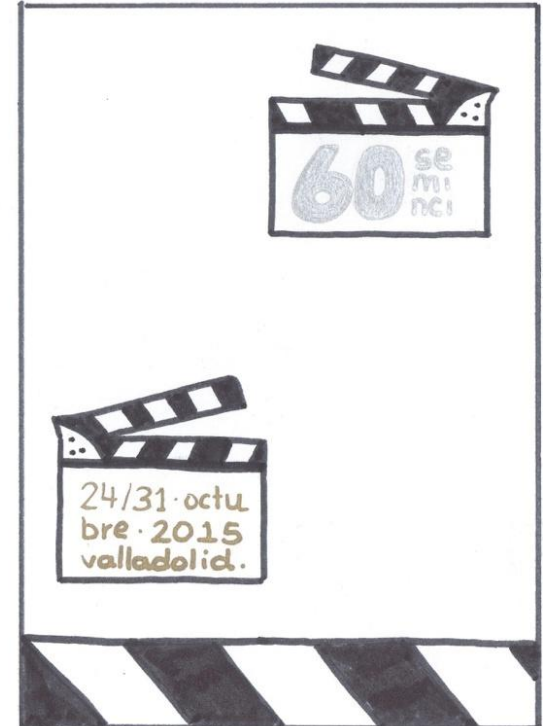
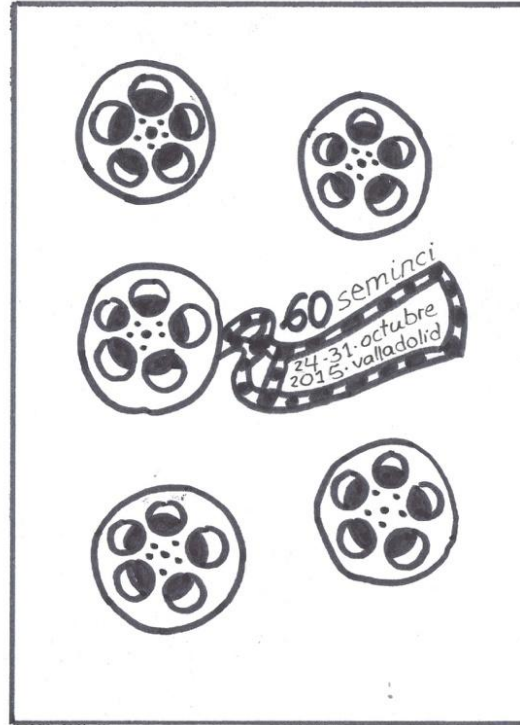
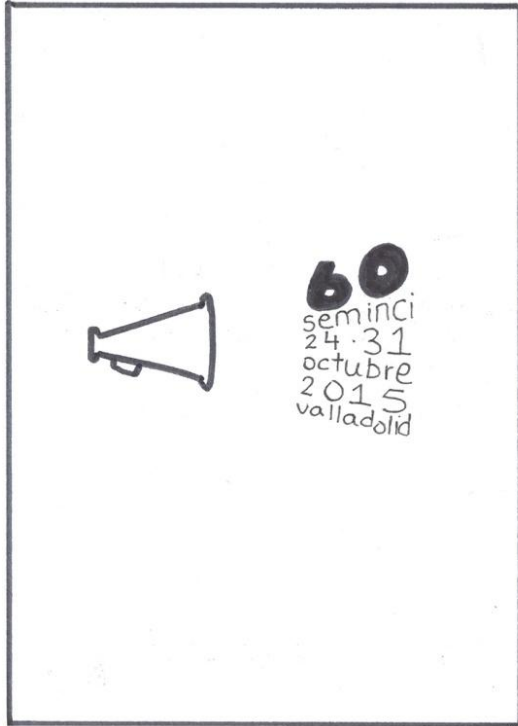

Jorge Jiménez Gutiérrez
Prof. Víctor A. Lafuente Sánchez

Cartelería para la 60 Seminci a partir del esquema de peso visual de tres fotografías
Posters for 60 Seminci from visual weight scheme of three photographs

tallerdediseño

1

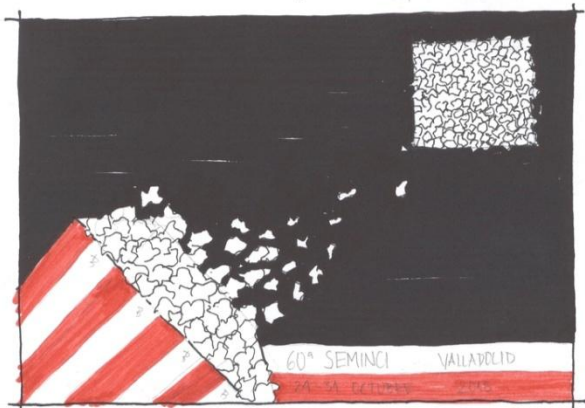
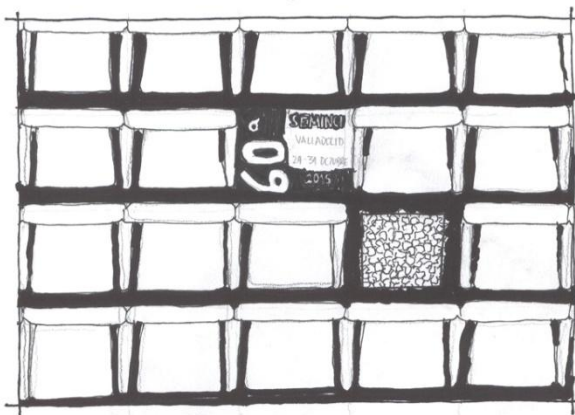
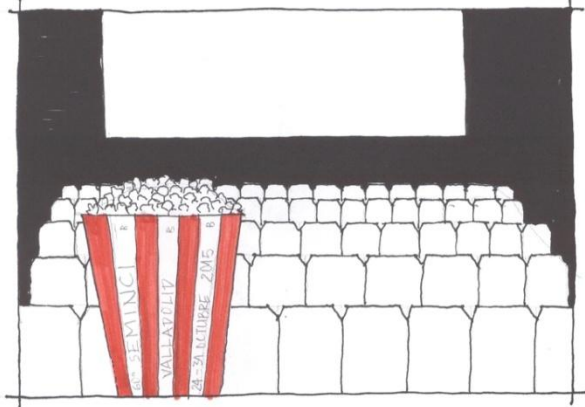

Cauê Massuda Ortiz Volpe
Prof. Víctor A. Lafuente Sánchez

Cartelería para la 60 Seminci a partir del esquema de peso visual de tres fotografías
Posters for 60 Seminci from visual weight scheme of three photographs

tallerdediseño

1

A B C D E F G H I
J K L M N Ñ O P Q
R S T U V W X Y Z

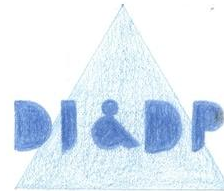
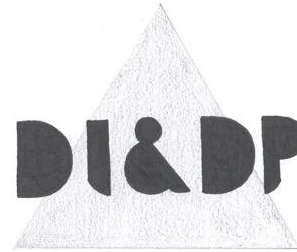
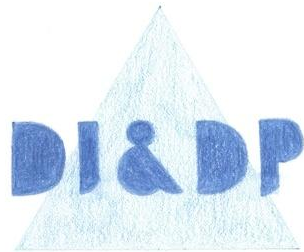

GRADO EN INGENIERIA EN
DISEÑO INDUSTRIAL Y DESARROLLO
DE PRODUCTO

Lucía Brazuelo Cabeza
Prof. Víctor A. Lafuente Sánchez

Logotipo para el Grado en Ingeniería en Diseño Industrial y Desarrollo del Producto
Logo for the Industrial Design Engineering and Product Development Degree

tallerdediseño

1

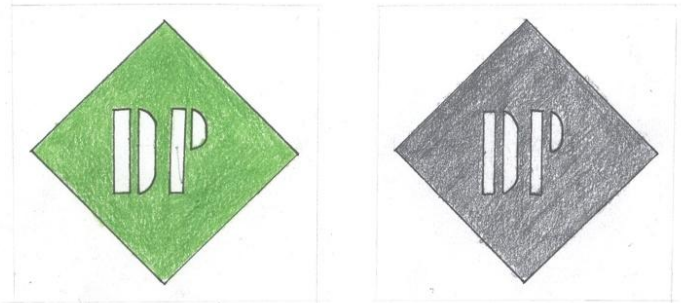

Diseño y Desarrollo del Producto

A B C D E F G H I J K L M N Ñ

O P Q R S T U V W

a b c d e f g h i j k l m n ñ o p q r s t u v

Marta Garrido García

Prof. Víctor A. Lafuente Sánchez

Logotipo para el Grado en Ingeniería en Diseño Industrial y Desarrollo del Producto
Logo for the Industrial Design Engineering and Product Development Degree

tallerdediseño

1

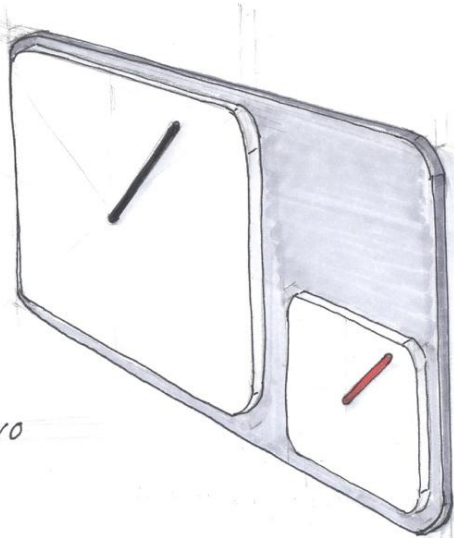

ADITIVO

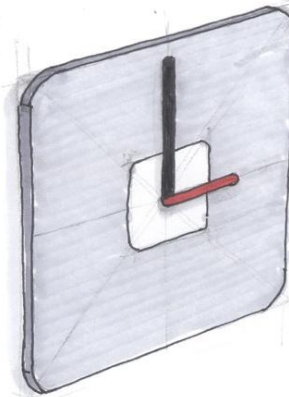

INTEGRATIVO

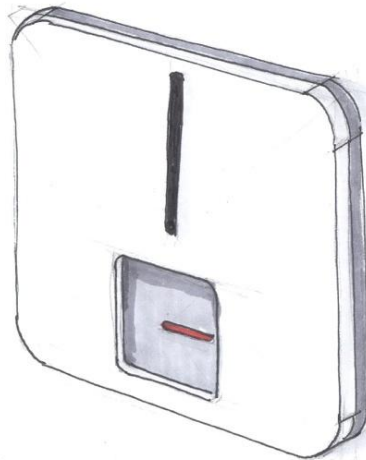

INTEGRAL

José Juan Esteban Higelmo
Prof. Víctor A. Lafuente Sánchez

Diseño de reloj mediante los procesos aditivo, integrativo e integral
Clock design by the additive, integrative and integral processes

tallerdediseño

1

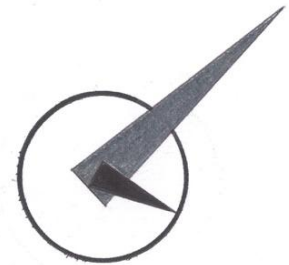
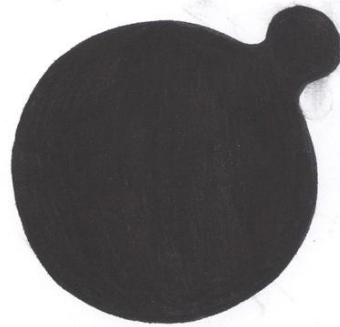
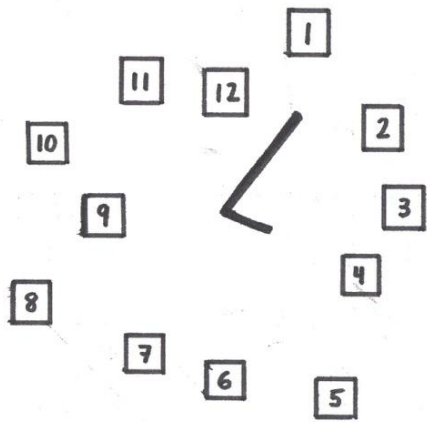

Laura Sanz Cañal

Prof. Víctor A. Lafuente Sánchez

Diseño de reloj mediante los procesos aditivo, integrativo e integral
Clock design by the additive, integrative and integral processes

tallerdediseño

1



Celia Pascual Mitre

Prof. Víctor A. Lafuente Sánchez

Diseño de lámpara mediante los procesos aditivo, integrativo e integral
Lamp design by the additive, integrative and integral processes

tallerdediseño

1

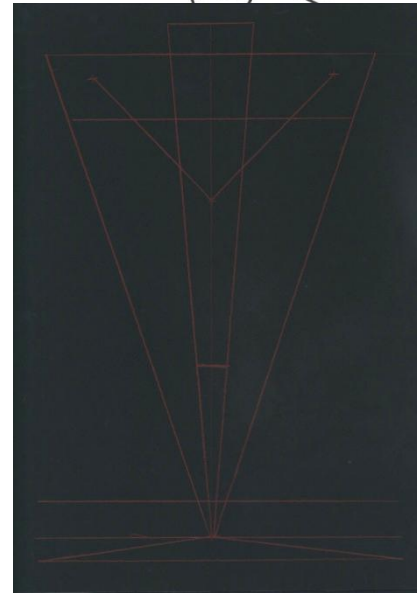
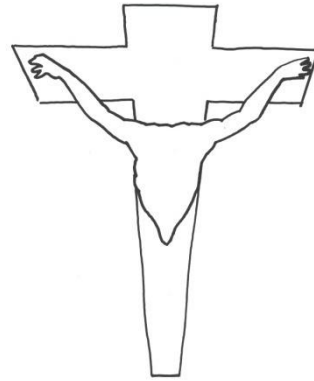
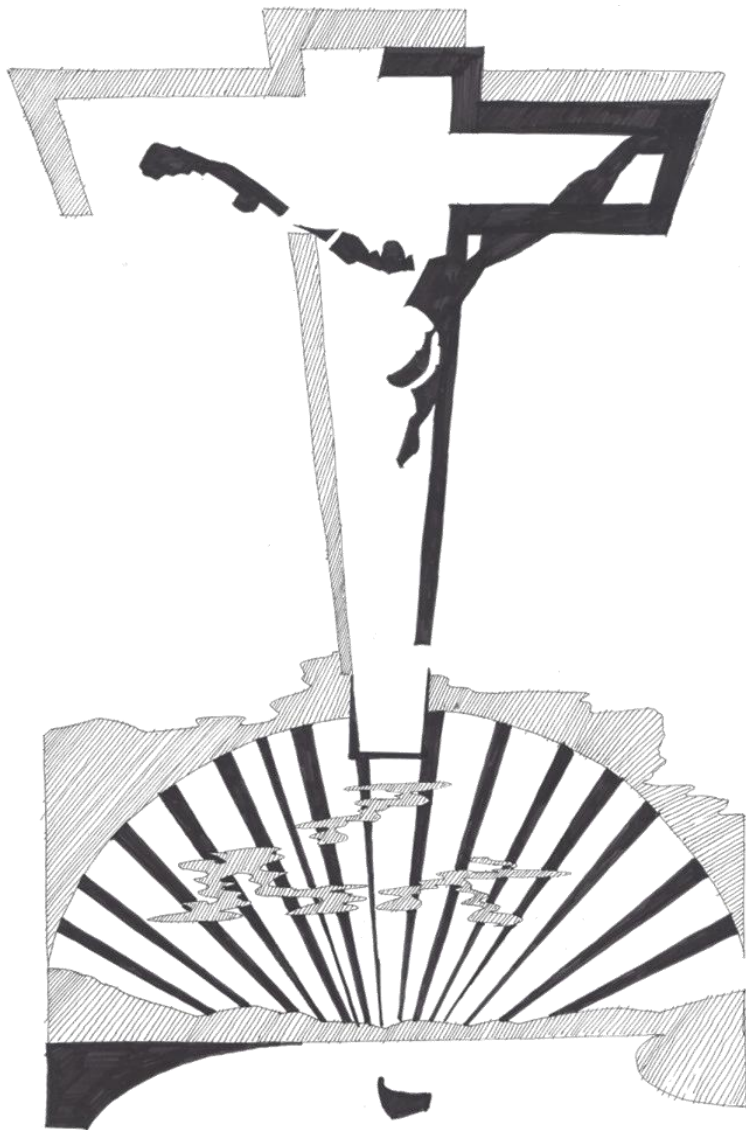

José Juan Esteban Higelmo
Prof. Víctor A. Lafuente Sánchez

Análisis gráfico de "Cristo de San Juan de la Cruz", de Salvador Dalí
Graphic analysis of "Christ of Saint John of the Cross", by Salvador Dalí

tallerdediseño

1

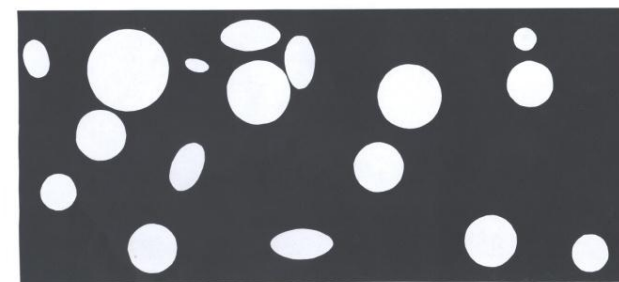
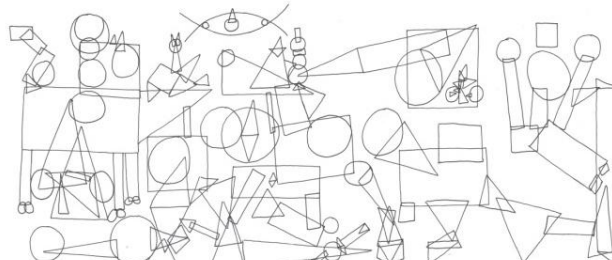
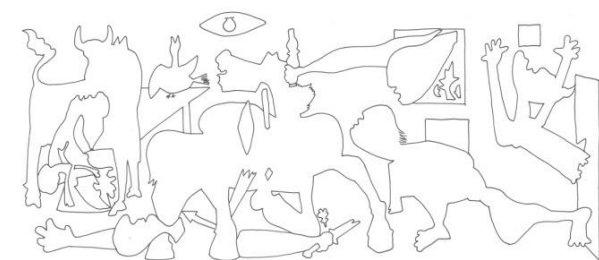
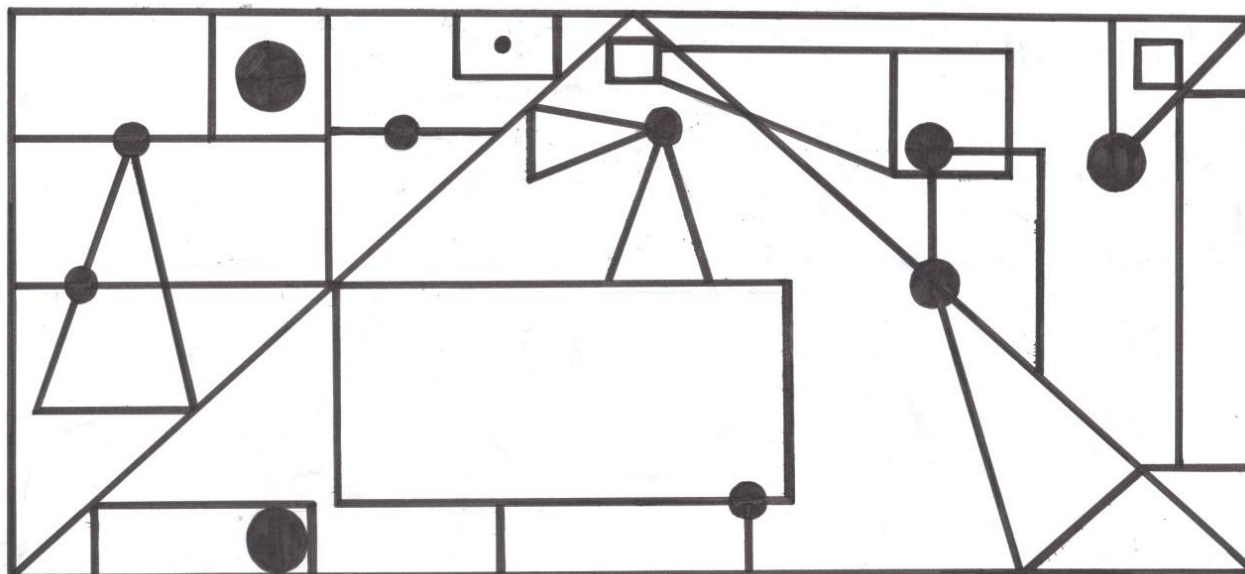
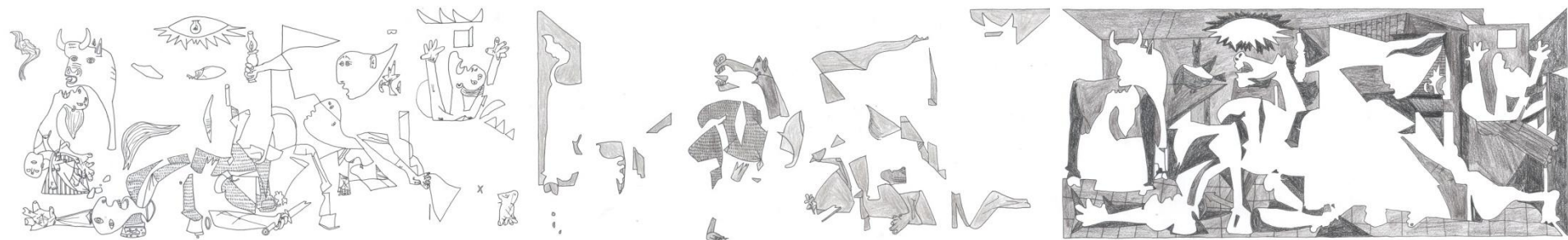

Francisco Yuste Pablo
Prof. Víctor A. Lafuente Sánchez

Análisis gráfico de "Guernica", de Pablo Picasso
Graphic analysis of "Guernica", by Pablo Picasso

tallerdediseño



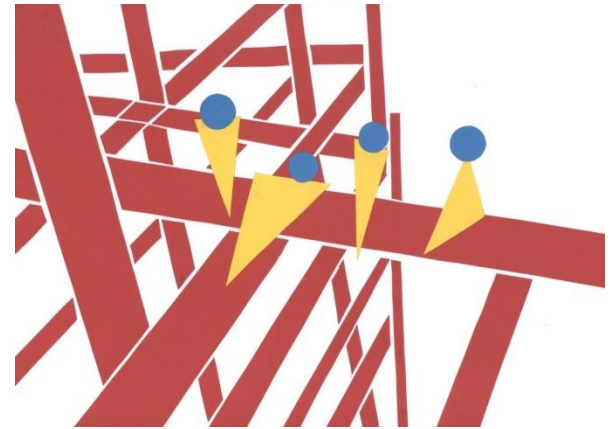
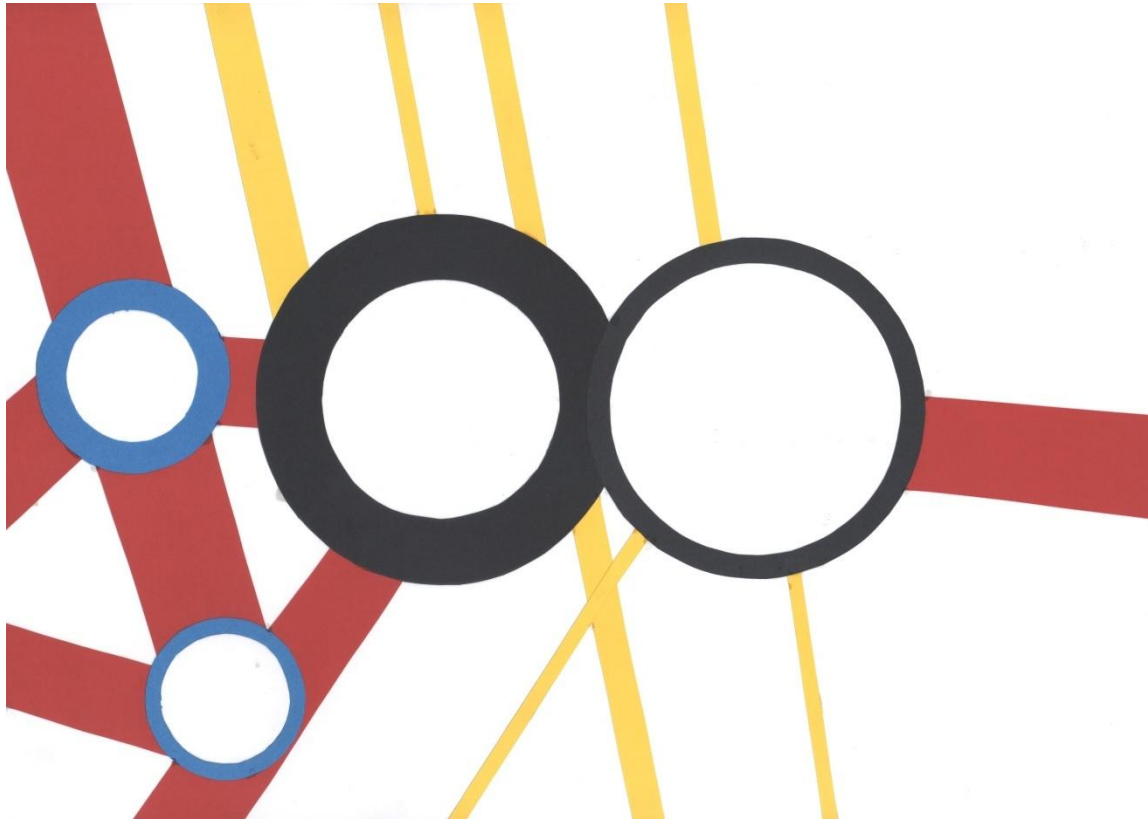
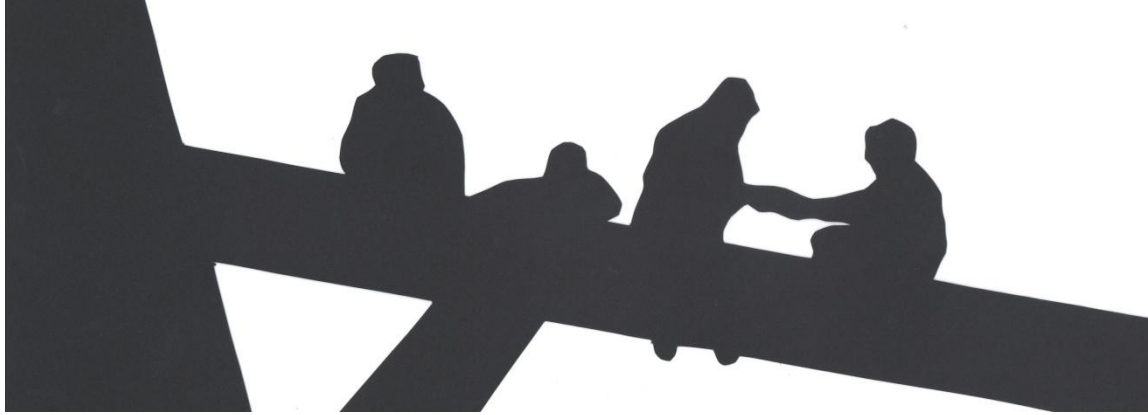

Álvaro Blanco López
Prof. Víctor A. Lafuente Sánchez

Análisis gráfico de “Almuerzo en la cima de un rascacielos”, de Charles Ebbets
Graphic analysis of “Lunch atop a Skyscraper”, by Charles Ebbets

tallerdediseño

1

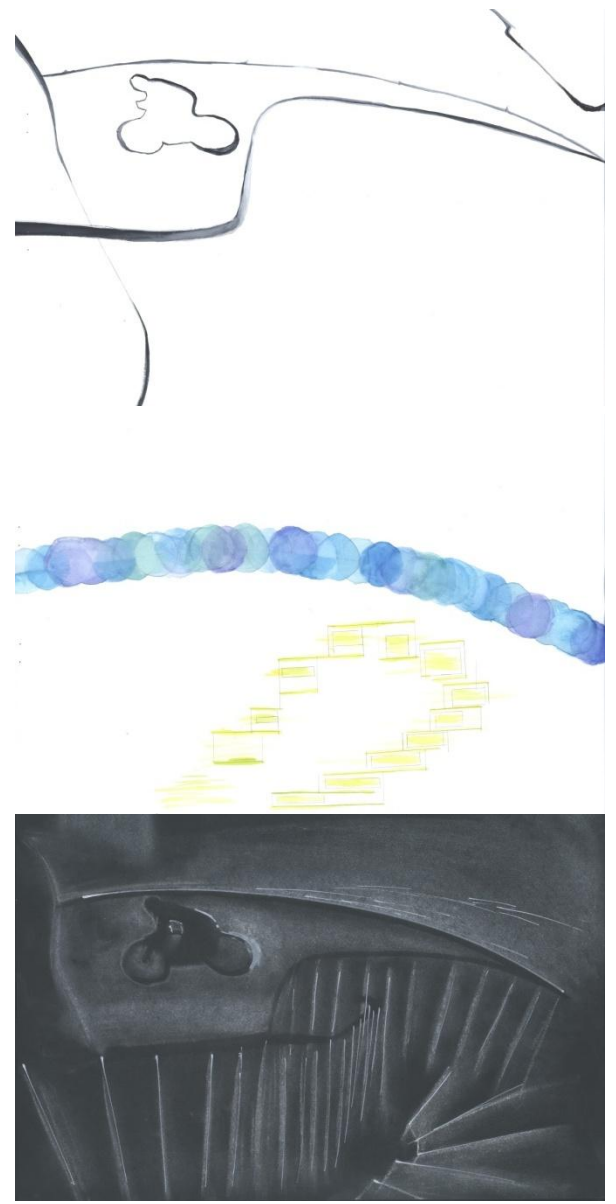

Claudia González Peral
Prof. Víctor A. Lafuente Sánchez

Análisis gráfico de "Hyères, Francia", de Henri Cartier-Bresson
Graphic analysis of "Hyères, France", by Henri Cartier-Bresson

tallerdediseño

1



Andrea Denis Carel Ayuso
Prof. Víctor A. Lafuente Sánchez

Objeto analítico a partir de "Las Artes: Danza", de Alphonse Mucha
Analytical object from "The Arts: Dance", by Alphonse Mucha

tallerdediseño

1



Álvaro González Huertas

Prof. Víctor A. Lafuente Sánchez

Objeto analítico a partir de "Guitarra Eléctrica", de Erik Johansson
Analytical object from "Electric Guitar", by Erik Johansson

tallerdediseño

1



Claudia González Peral
Prof. Víctor A. Lafuente Sánchez

Objeto analítico a partir "Hyères, Francia", de Henri Cartier-Bresson
Analytical object from "Hyères, France", by Henri Cartier-Bresson

tallerdediseño

1



Beatriz Torre Agúndez
Prof. Víctor A. Lafuente Sánchez

Objeto analítico a partir de "Los Halcones de la Noche", de Edward Hopper
Analytical object from "Nighthawks", by Edward Hopper

tallerdediseño

1

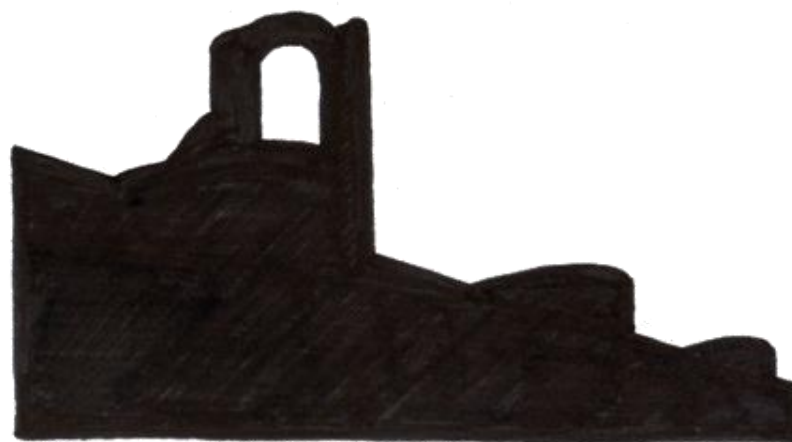

LUGO

VILLA ROMANA

Darío José Álvarez Gayoso
Prof. Víctor A. Lafuente Sánchez

Imagen corporativa para la ciudad de Lugo
Corporate image for the city of Lugo

tallerdediseño





Irene Prieto Salvador

Prof. Víctor A. Lafuente Sánchez

Imagen corporativa para la ciudad de Zamora
Corporate image for the city of Zamora

tallerdediseño



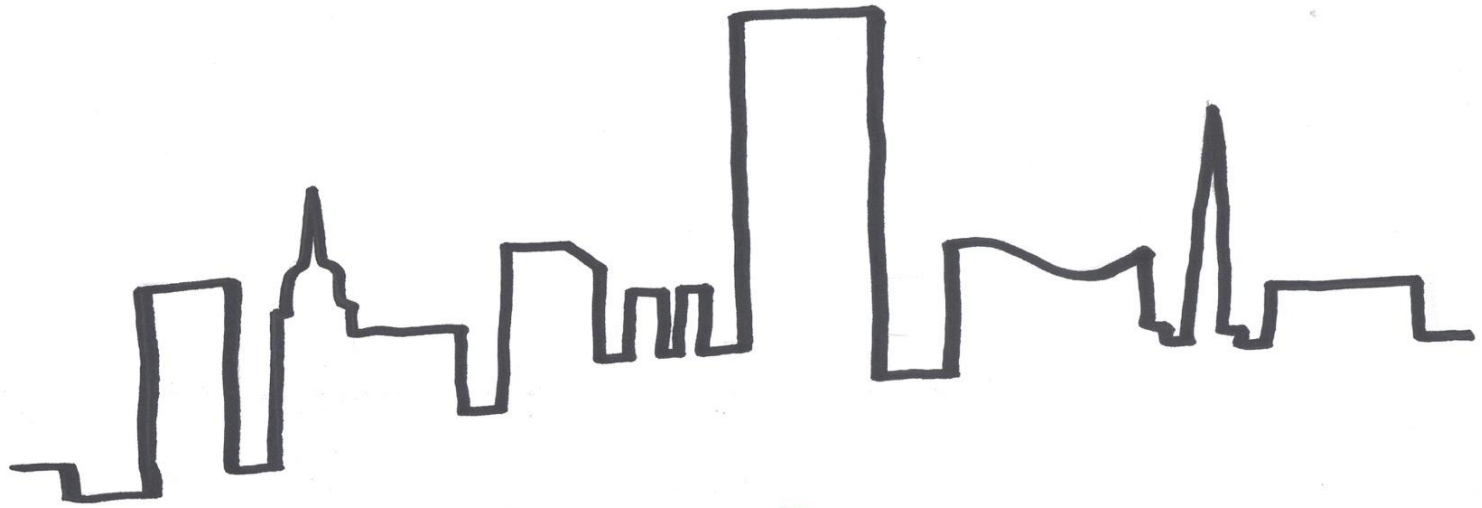

São Paulo

Cauê Massuda Ortiz Volpe
Prof. Víctor A. Lafuente Sánchez

Imagen corporativa para la ciudad de Sao Paulo
Corporate image for the city of Sao Paulo

tallerdediseño

1

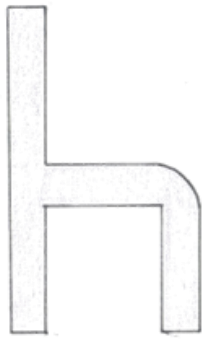

aula

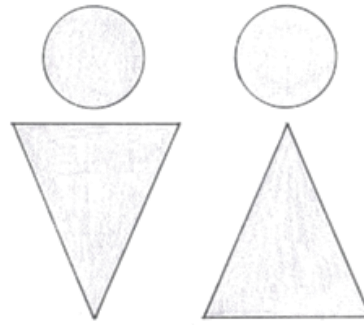

aseo

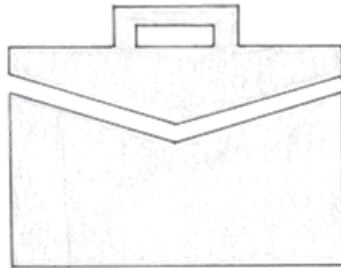

despacho

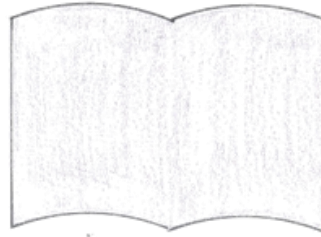

biblioteca

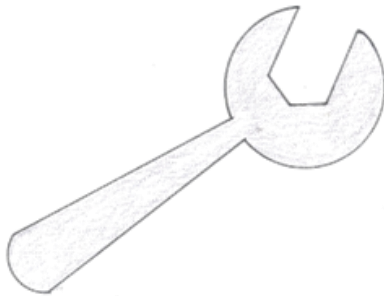

taller

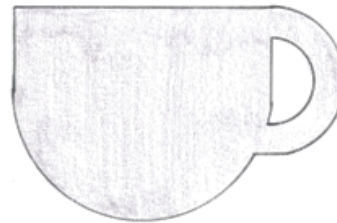

cafetería

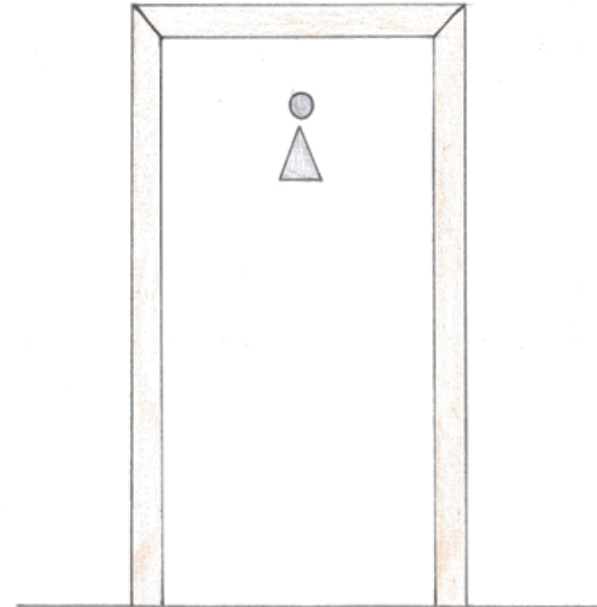

Placas metálicas colocadas directamente sobre la puerta .

Lucía Brazuelo Cabeza
Prof. Víctor A. Lafuente Sánchez

Señalética para la Escuela de Ingenierías Industriales
Signage for the School of Industrial Engineering

tallerdediseño

1

Aula



Despacho



Taller



Aseos



Biblioteca



Cafeteria

Rodrigo Domínguez Fernández
 Prof. Víctor A. Lafuente Sánchez

Señalética para la Escuela de Ingenierías Industriales
Signage for the School of Industrial Engineering

tallerdediseño



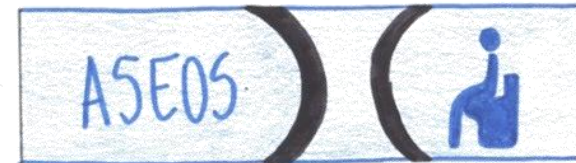
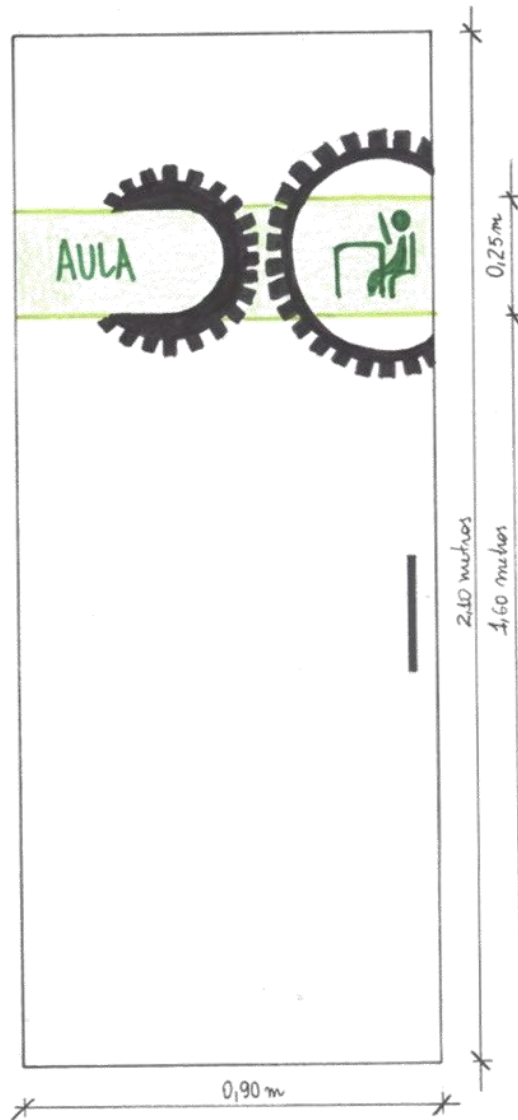

Aline Matías Alves
 Prof. Víctor A. Lafuente Sánchez

Señalética para la Escuela de Ingenierías Industriales
Signage for the School of Industrial Engineering

tallerdediseño

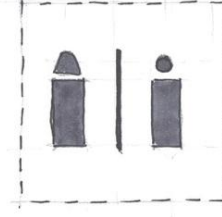
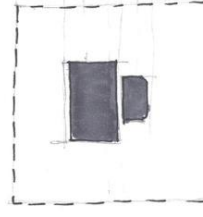
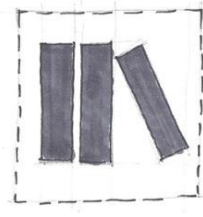
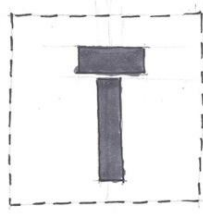
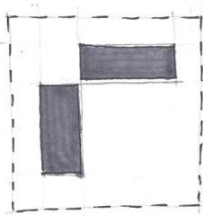
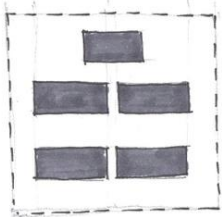
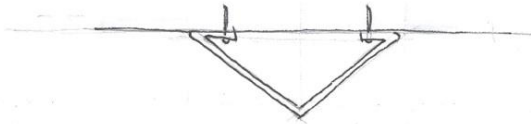
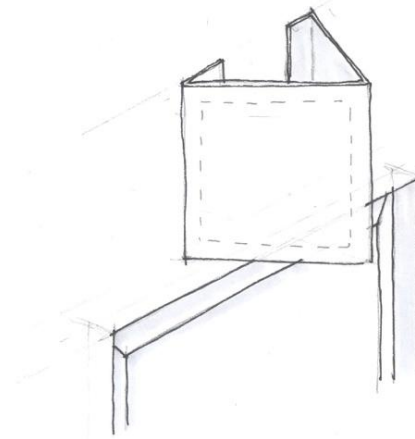
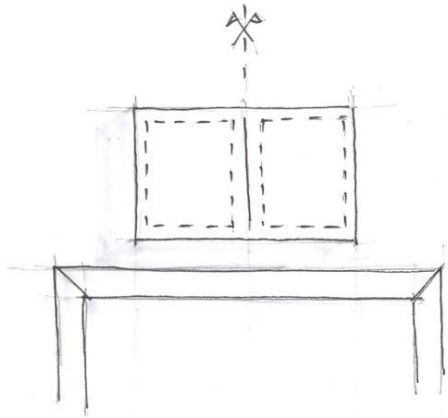

José Juan Esteban Higelmo
Prof. Víctor A. Lafuente Sánchez

Señalética para la Escuela de Ingenierías Industriales
Signage for the School of Industrial Engineering

tallerdediseño





Cauê Massuda Ortiz Volpe
 Prof. Víctor A. Lafuente Sánchez

Señalética para la Escuela de Ingenierías Industriales
Signage for the School of Industrial Engineering

tallerdediseño

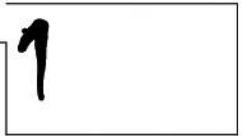

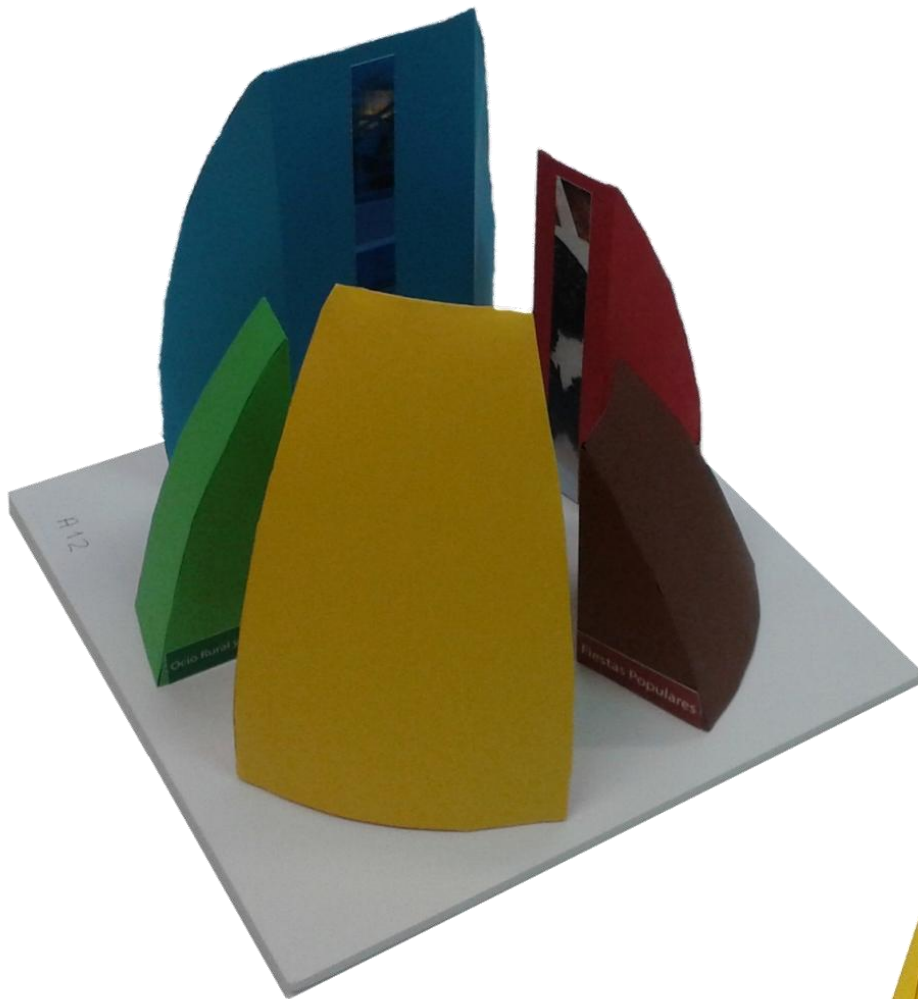

Andrea Denis Carel Ayuso
Prof. Víctor A. Lafuente Sánchez

Diseño de stand de la oferta turística de Castilla y León para INTUR 2015
Stand design about Castile tourist offer for INTUR 2015

tallerdediseño





Mariano José Salazar Lozano
Prof. Víctor A. Lafuente Sánchez

Diseño de stand de la oferta turística de Castilla y León para INTUR 2015
Stand design about Castile tourist offer for INTUR 2015

tallerdediseño

1

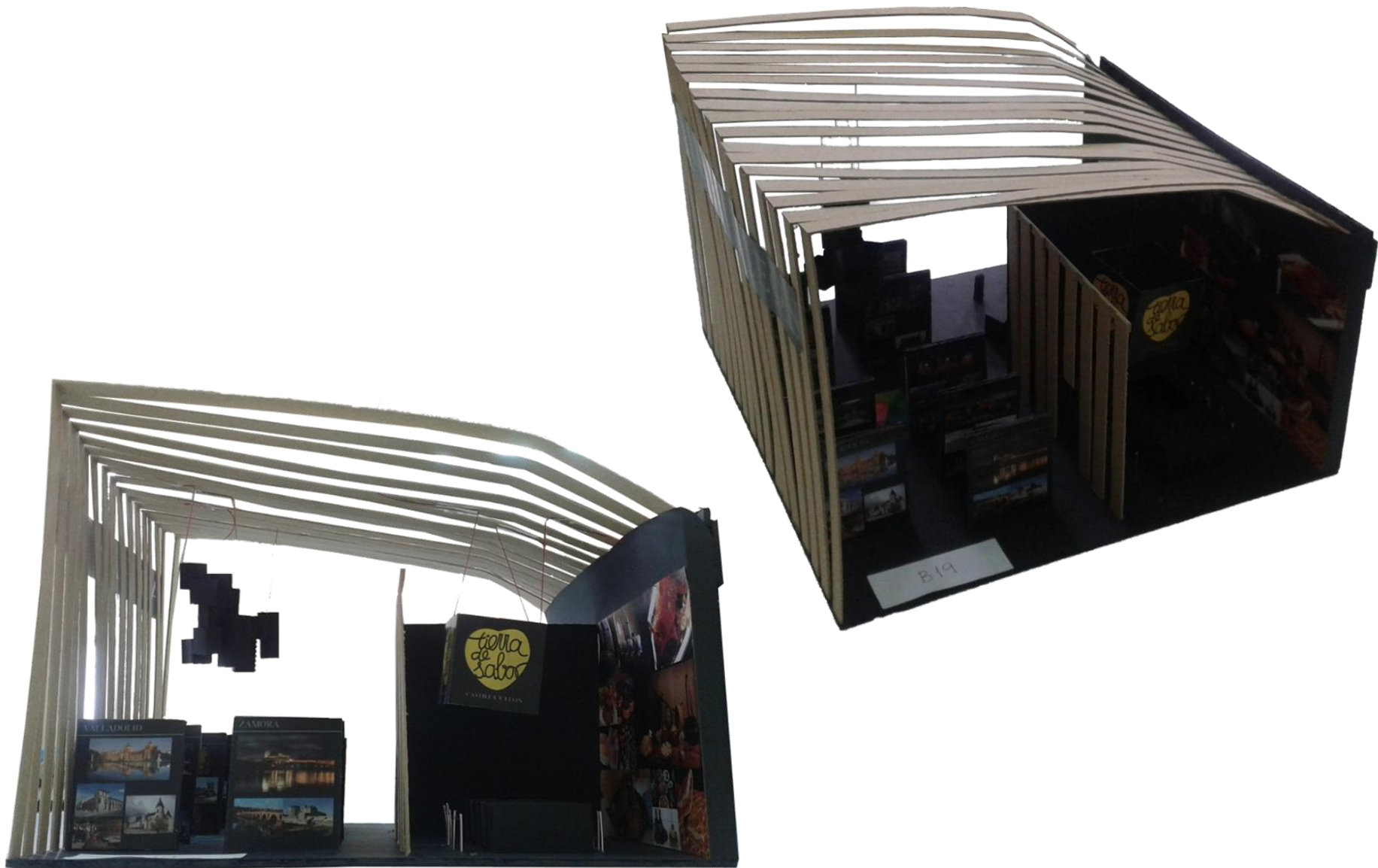

Sara Sánchez Lorenzo
Prof. Víctor A. Lafuente Sánchez

Diseño de stand de la oferta turística de Castilla y León para INTUR 2015
Stand design about Castile tourist offer for INTUR 2015

tallerdediseño





Jaime Perales García
Prof. Víctor A. Lafuente Sánchez

Diseño de stand de la oferta turística de Castilla y León para INTUR 2015
Stand design about Castile tourist offer for INTUR 2015

tallerdediseño





Miguel Carbayo Viejo
Prof. Víctor A. Lafuente Sánchez

Diseño de stand de la oferta turística de Castilla y León para INTUR 2015
Stand design about Castile tourist offer for INTUR 2015

tallerdediseño

1

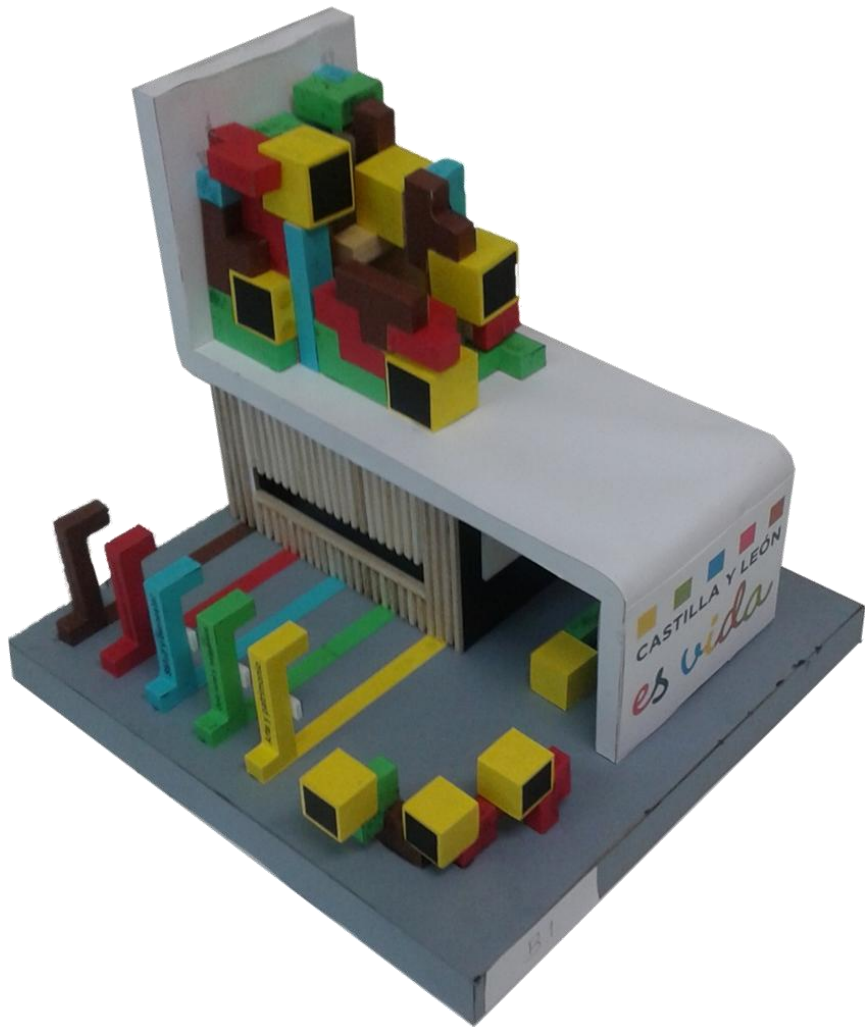

Álvaro Blanco López
Prof. Víctor A. Lafuente Sánchez

Diseño de stand de la oferta turística de Castilla y León para INTUR 2015
Stand design about Castile tourist offer for INTUR 2015

tallerdediseño

1

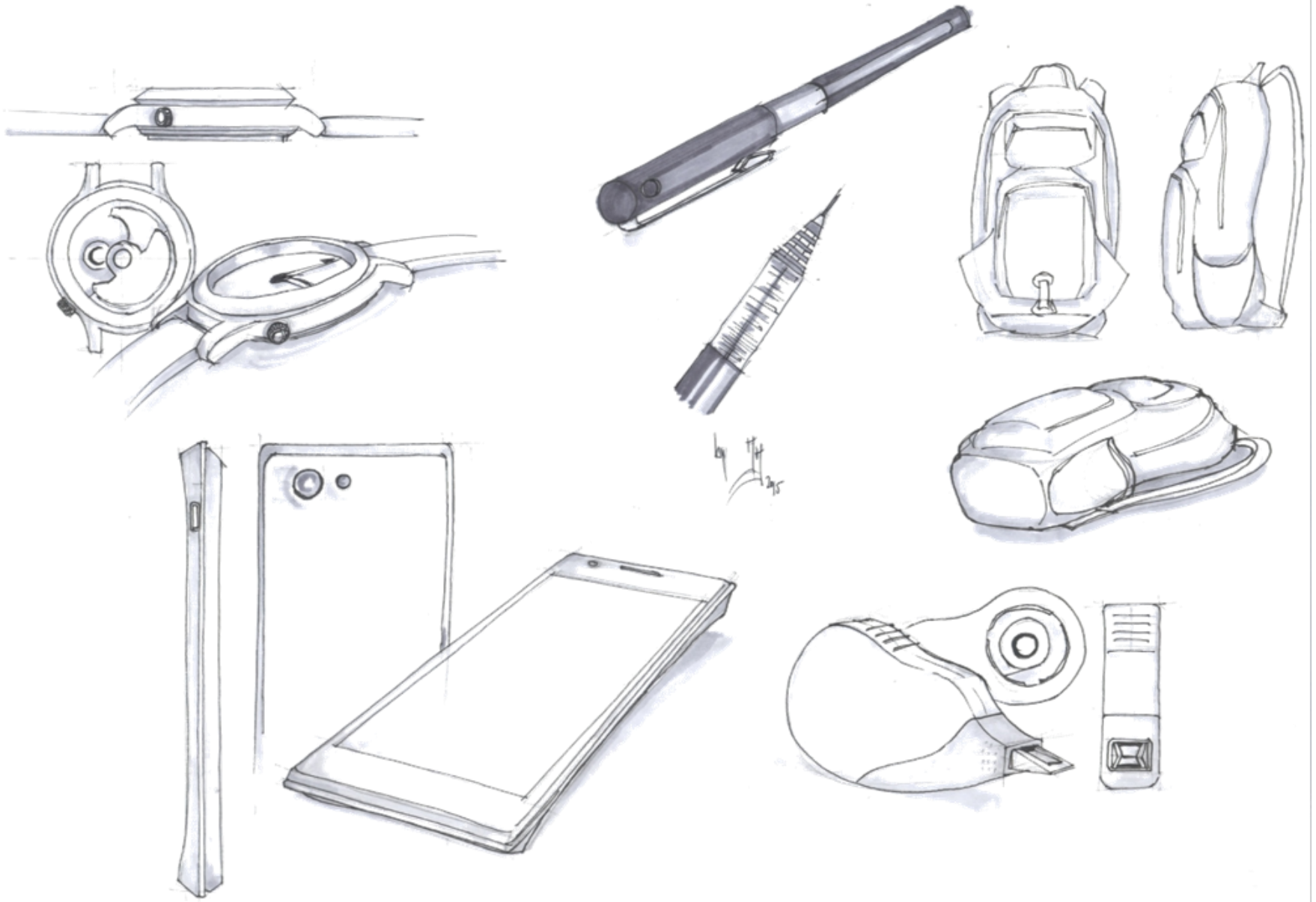

José Juan Esteban Higelmo
Prof. Víctor A. Lafuente Sánchez

Bocetaje de objetos cotidianos
Sketching of everyday objects

tallerdediseño

1



Álvaro Lucas Santos
Prof. Víctor A. Lafuente Sánchez

Bocetaje de objetos cotidianos
Sketching of everyday objects

tallerdediseño

1



Cauê Massuda Ortiz Volpe
Prof. Víctor A. Lafuente Sánchez

Bocetaje de objetos cotidianos
Sketching of everyday objects

tallerdediseño

1

log AQUARIS E5 FHD

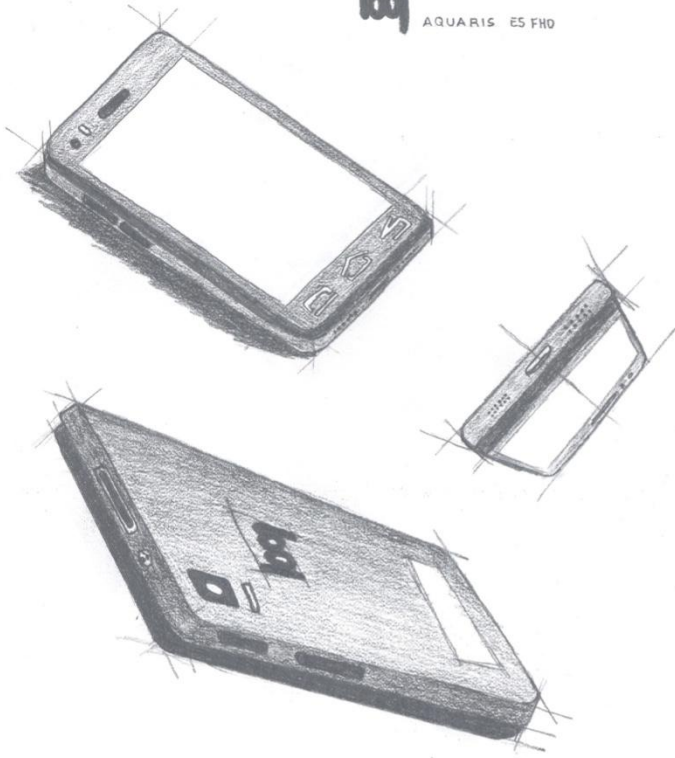

FABER - CASTELL

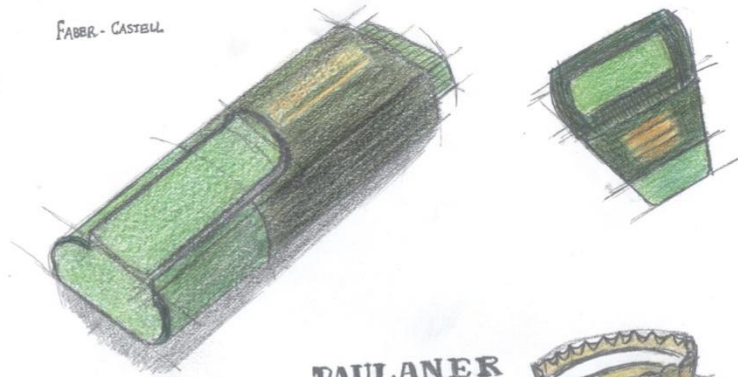

PAULANER

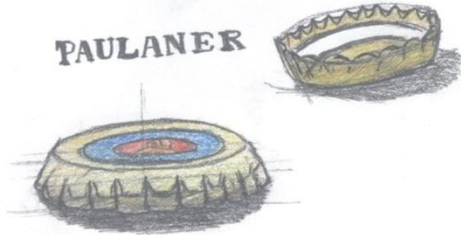

STAEDTLER

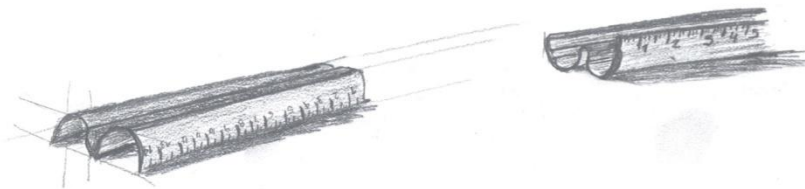
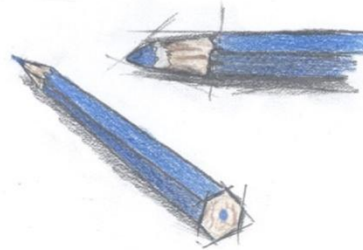

Javier Aracil Toval
Prof. Víctor A. Lafuente Sánchez

Bocetaje de objetos cotidianos
Sketching of everyday objects

tallerdediseño

1

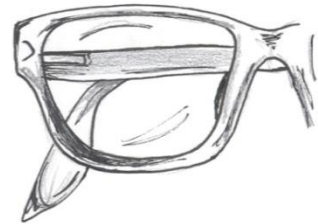
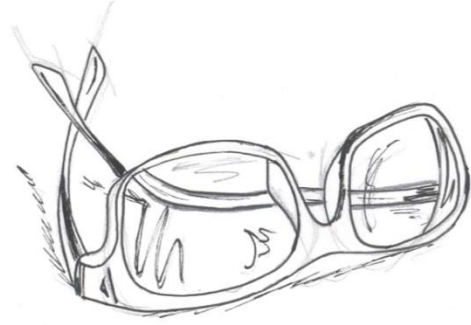
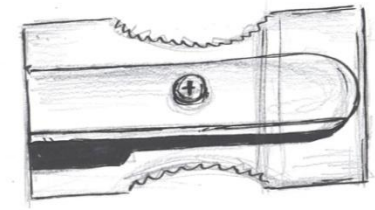
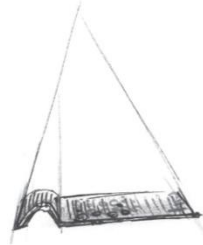
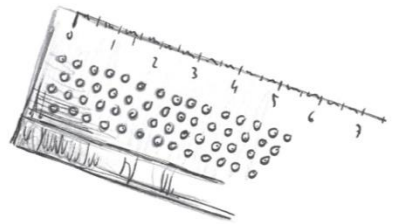
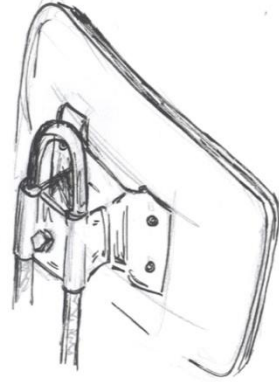

Jaime Perales García
Prof. Víctor A. Lafuente Sánchez

Bocetaje de objetos cotidianos
Sketching of everyday objects

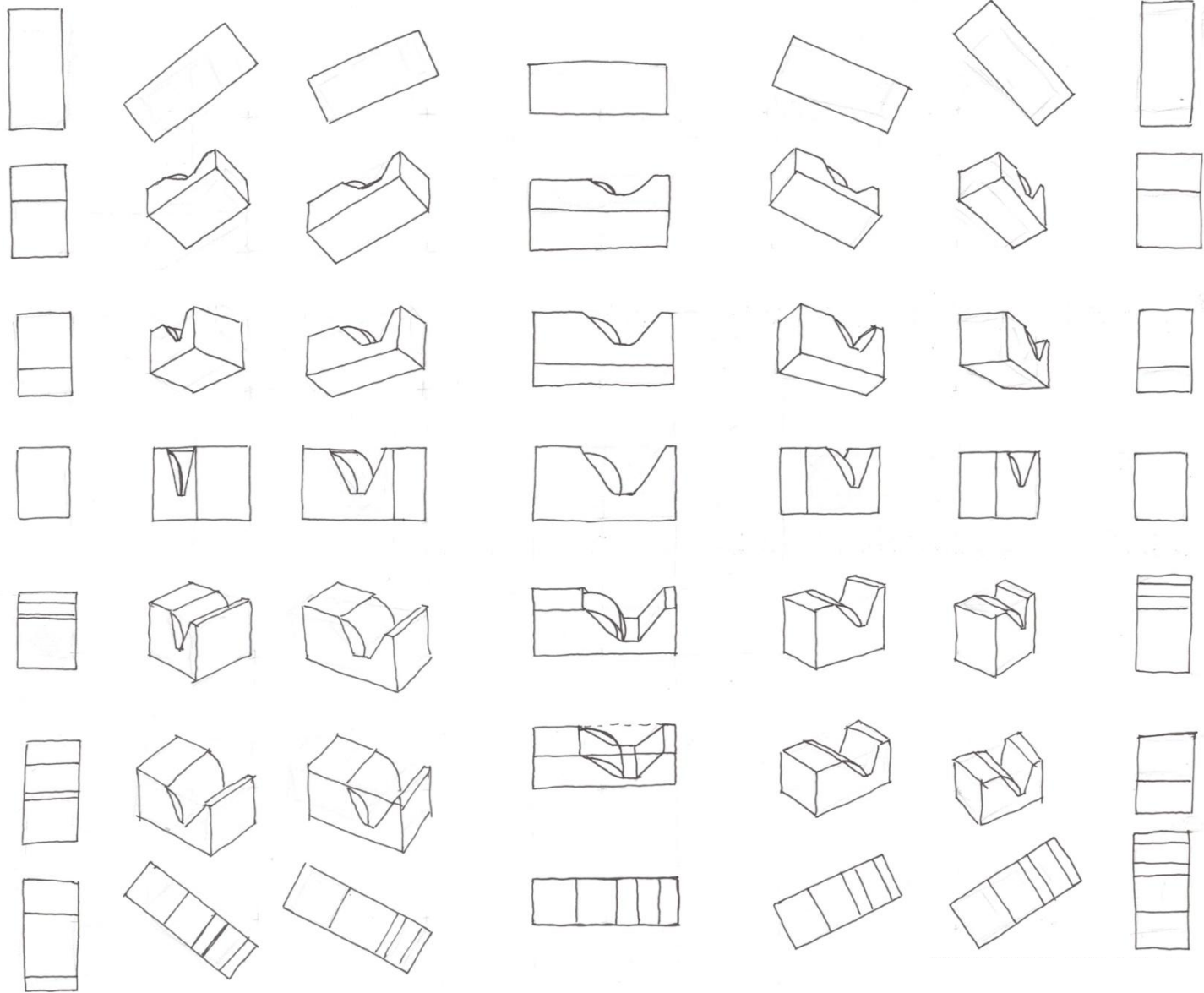

Mariano José Salazar Lozano
Prof. Víctor A. Lafuente Sánchez

Explosión volumétrica de un portarrollos de cinta adhesiva
Volumetric blast of adhesive tape holder

tallerdediseño

1

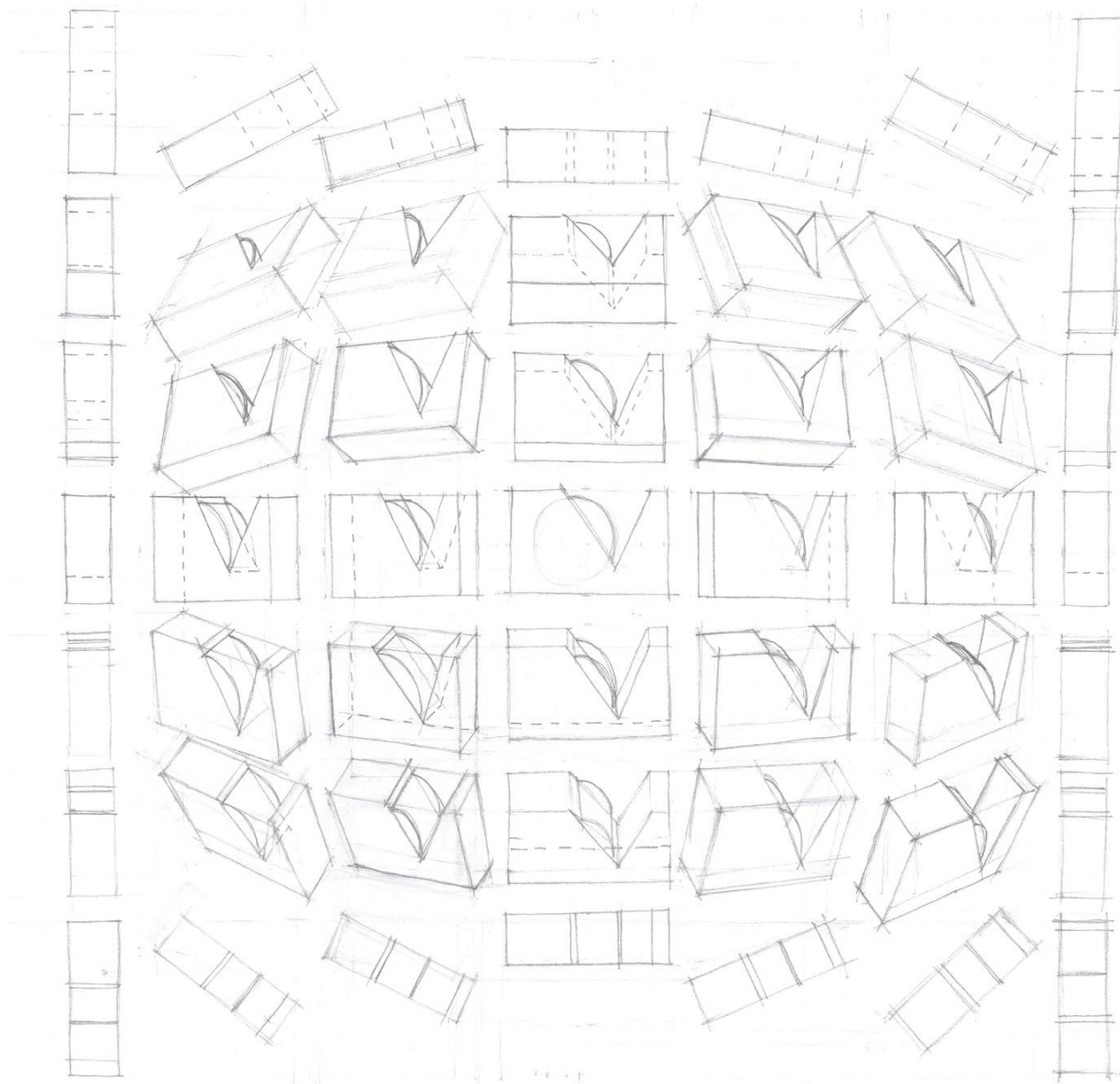

José Juan Esteban Higelmo
Prof. Víctor A. Lafuente Sánchez

Explosión volumétrica de un portarrollos de cinta adhesiva
Volumetric blast of adhesive tape holder

tallerdediseño

1

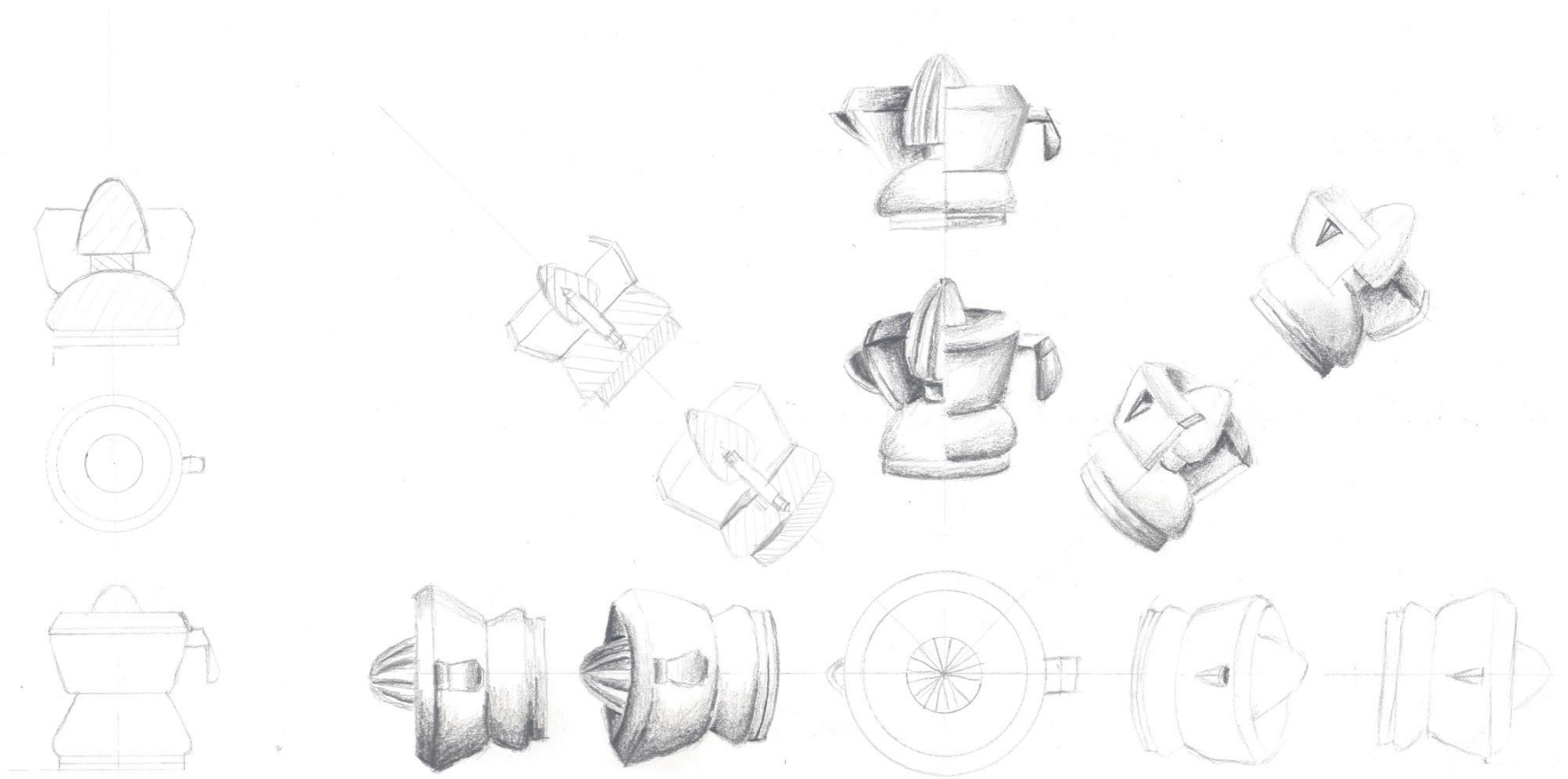

Cristina Corredera Martín
Prof. Víctor A. Lafuente Sánchez

Explosión volumétrica analítica de un exprimidor
Analytical volumetric blast of a juicer

tallerdediseño

1

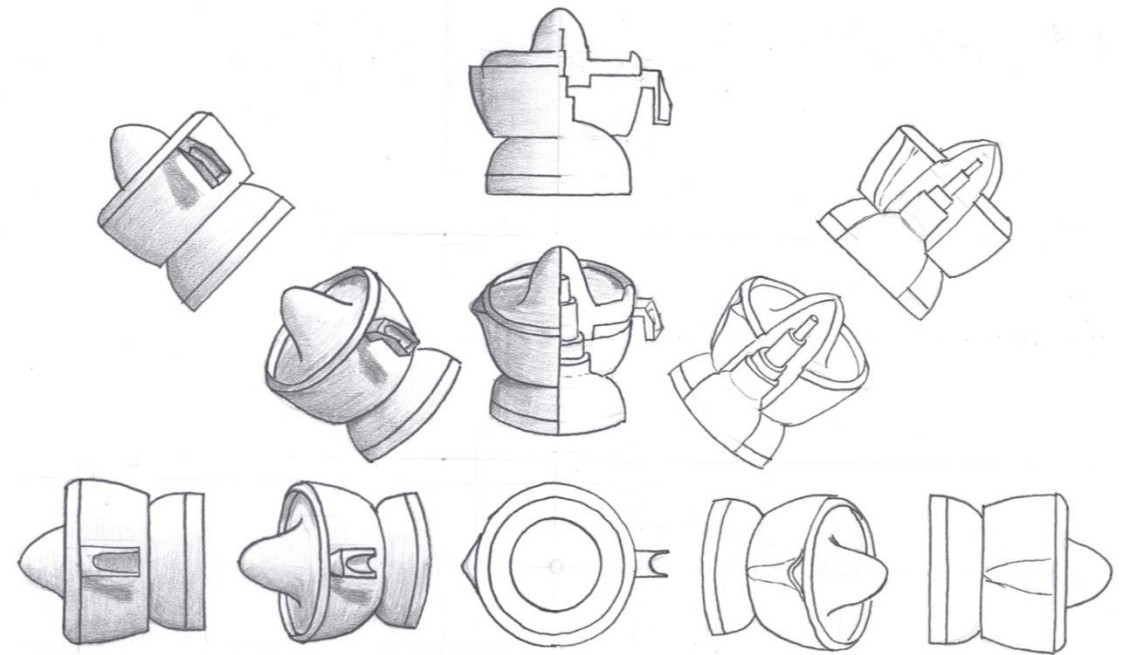
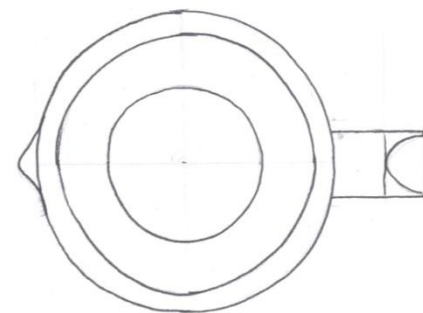
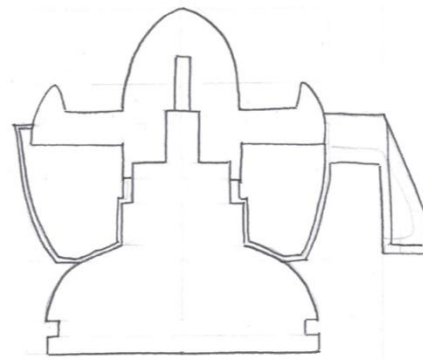
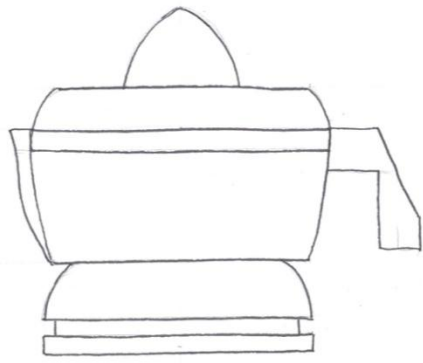

César Sánchez Martínez
Prof. Víctor A. Lafuente Sánchez

Explosión volumétrica analítica de un exprimidor
Analytical volumetric blast of a juicer